

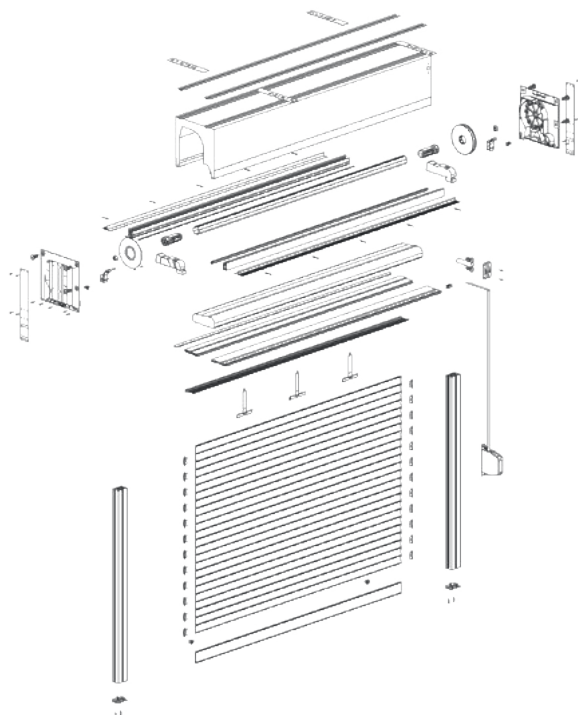

1. NÖTIGE WERKZEUGE ZUR DURCHFÜHRUNG DER MONTAGE

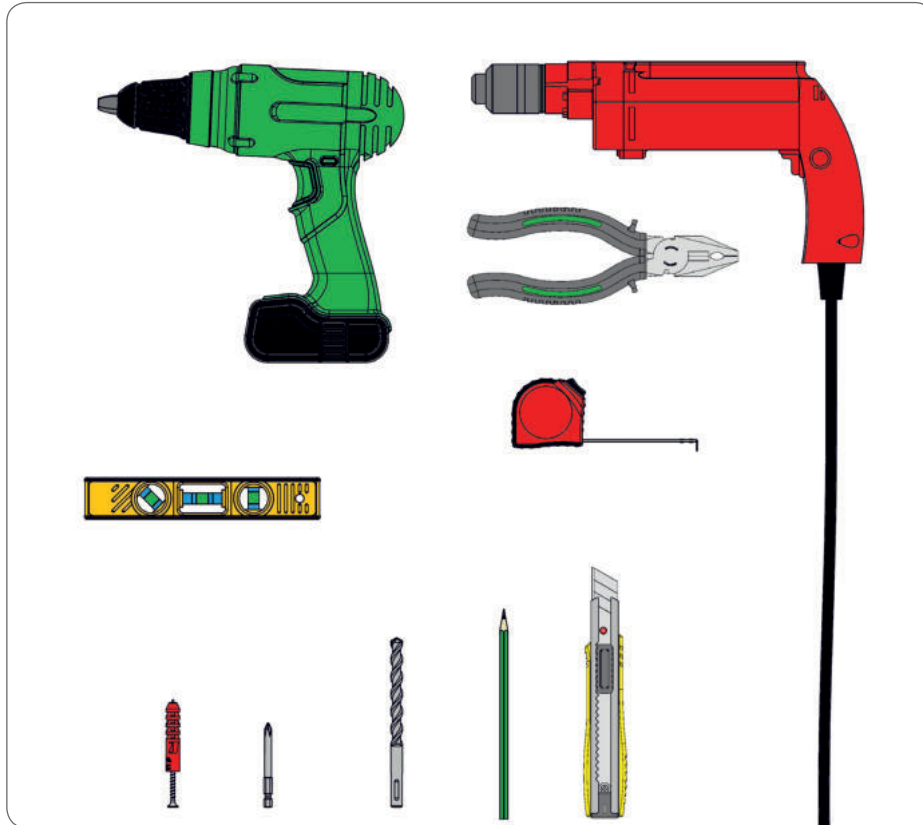

2. MESSUNG DES FENSTERS

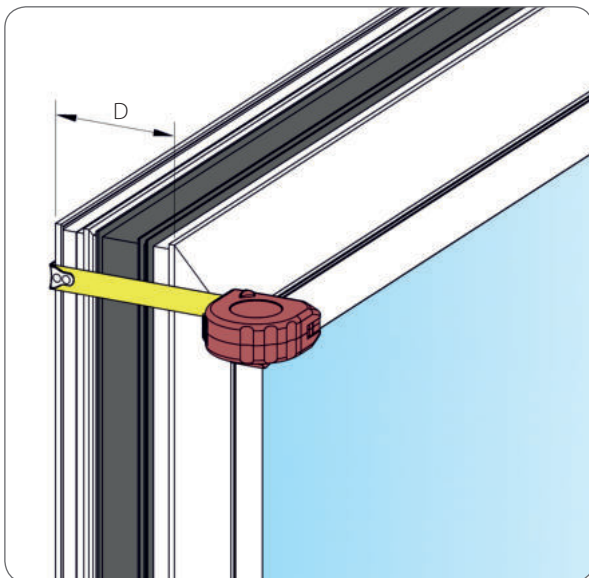
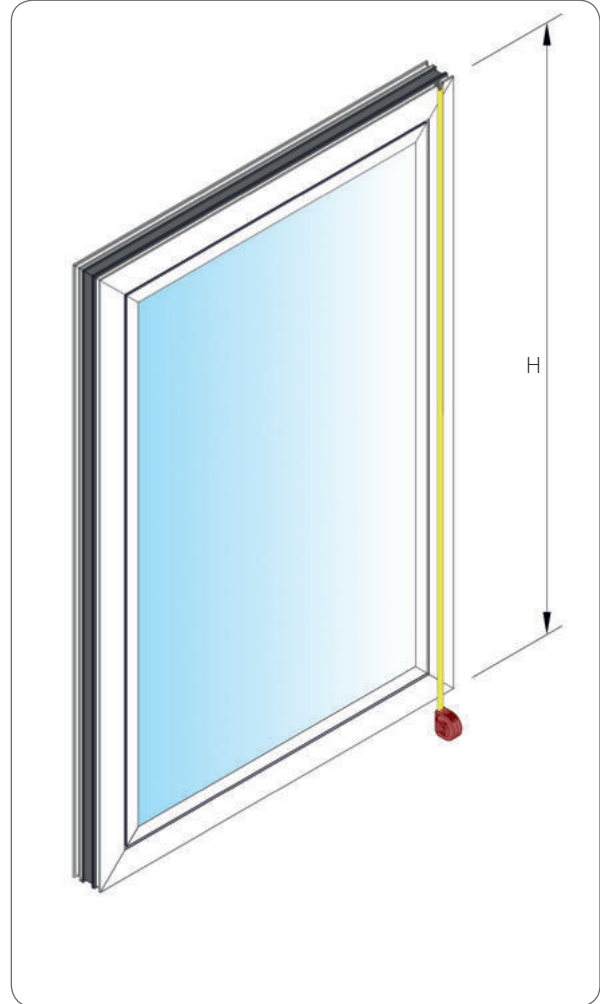
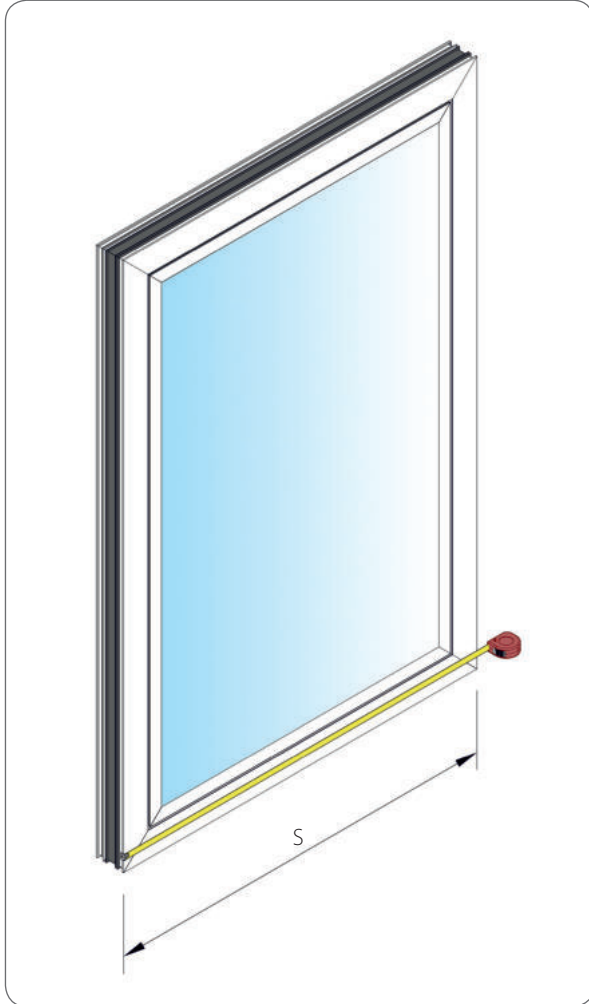

3. DIE REIHENFOLGE DER MONTAGE DES ROLLADENS IM AUFSATZSYSTEM MIT EINER REVISION VON INNEN SKB/RI

⚠ Bei Aluminiumfenstern sollten vor der Montage der Nypelschrauben Bohrungen von $\varnothing 2-2,5$ mm gemacht werden.

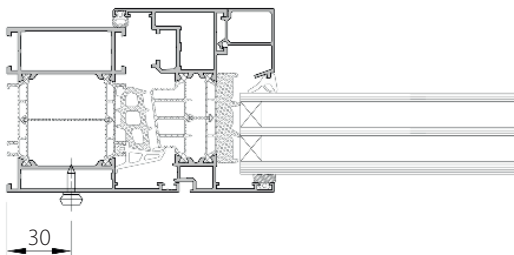
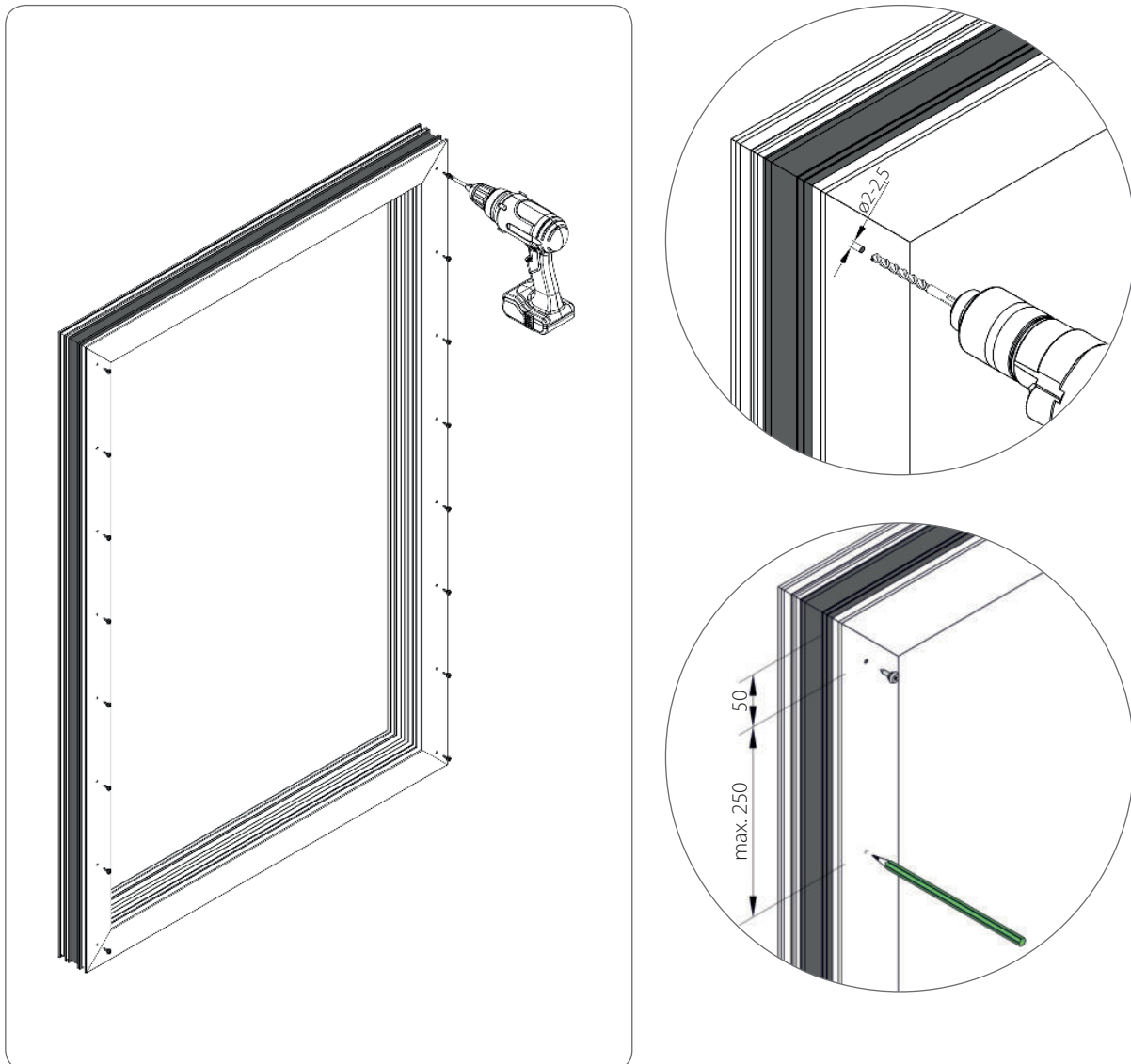

Führungsschienen: **PPDA60/12, PPDA60/17,**
PP60/12, PP60/17,
PPD60/12, PPD60/17,
PPDMW60/12, PPDMW60/17

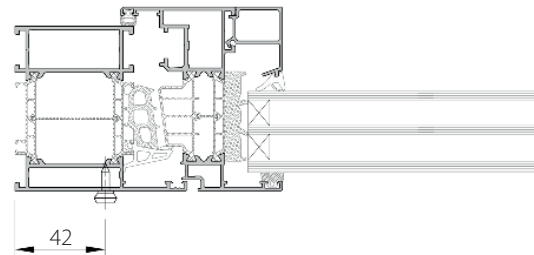

Führungsschienen: **PPA35/12, PPA35/17**

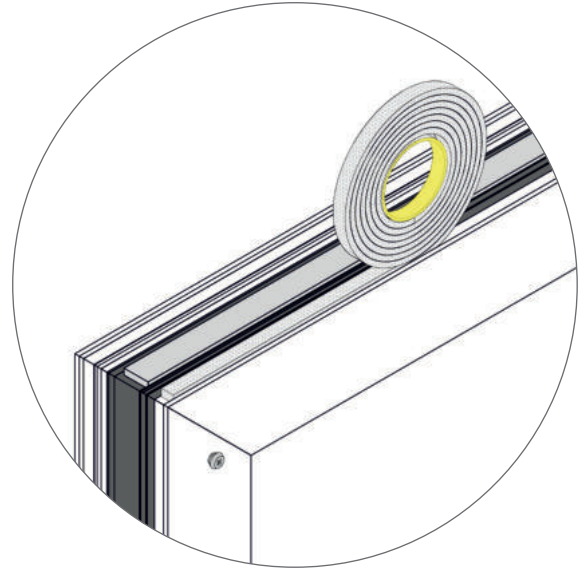
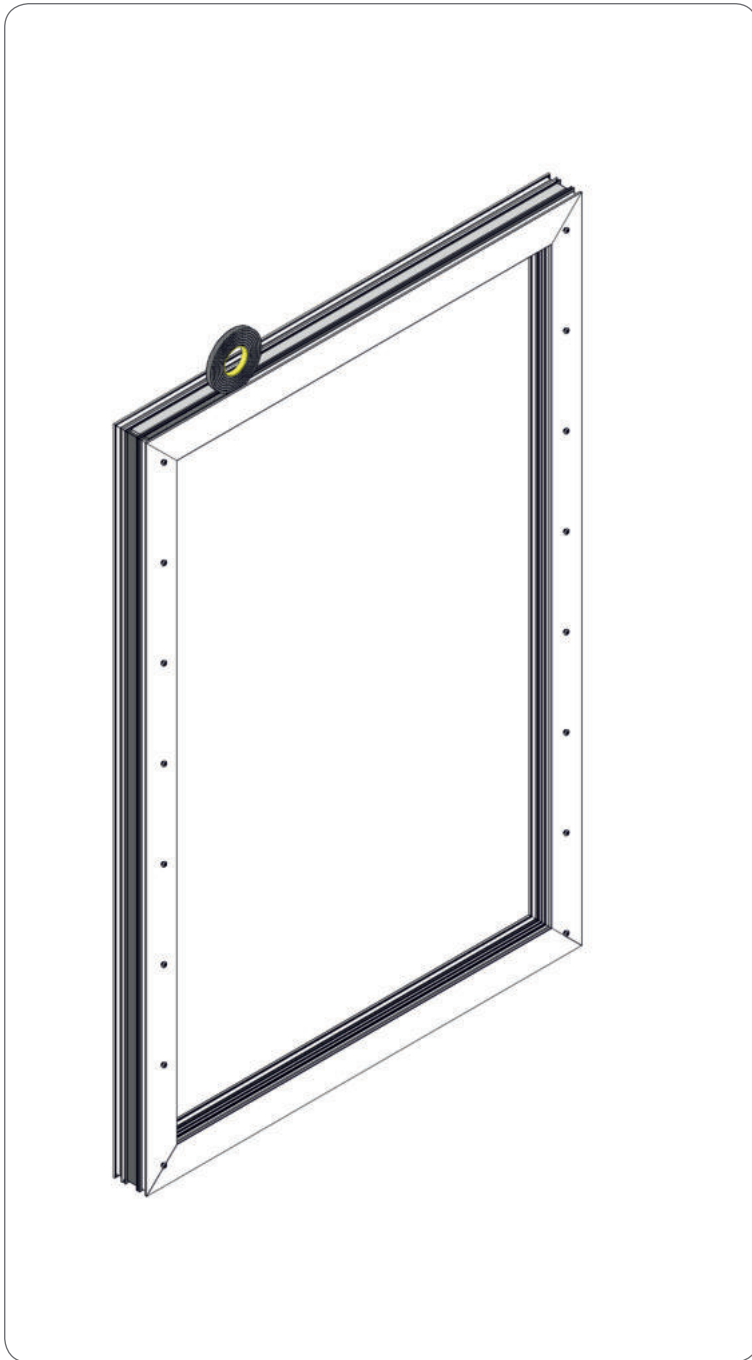

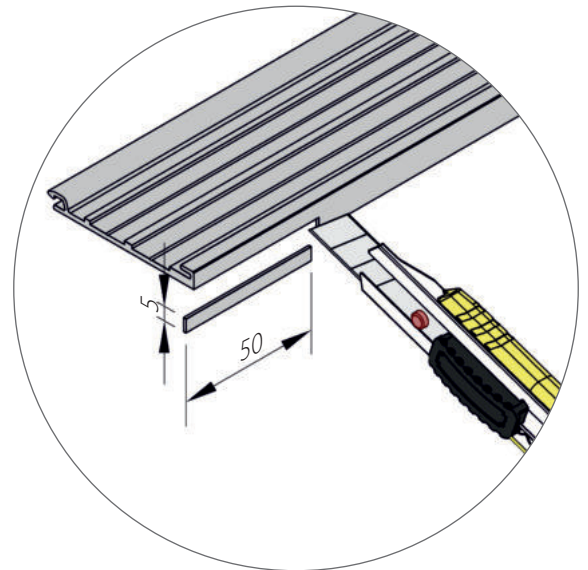
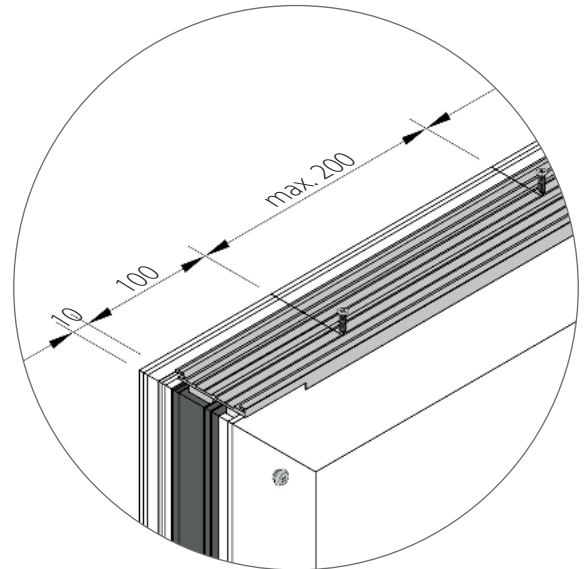
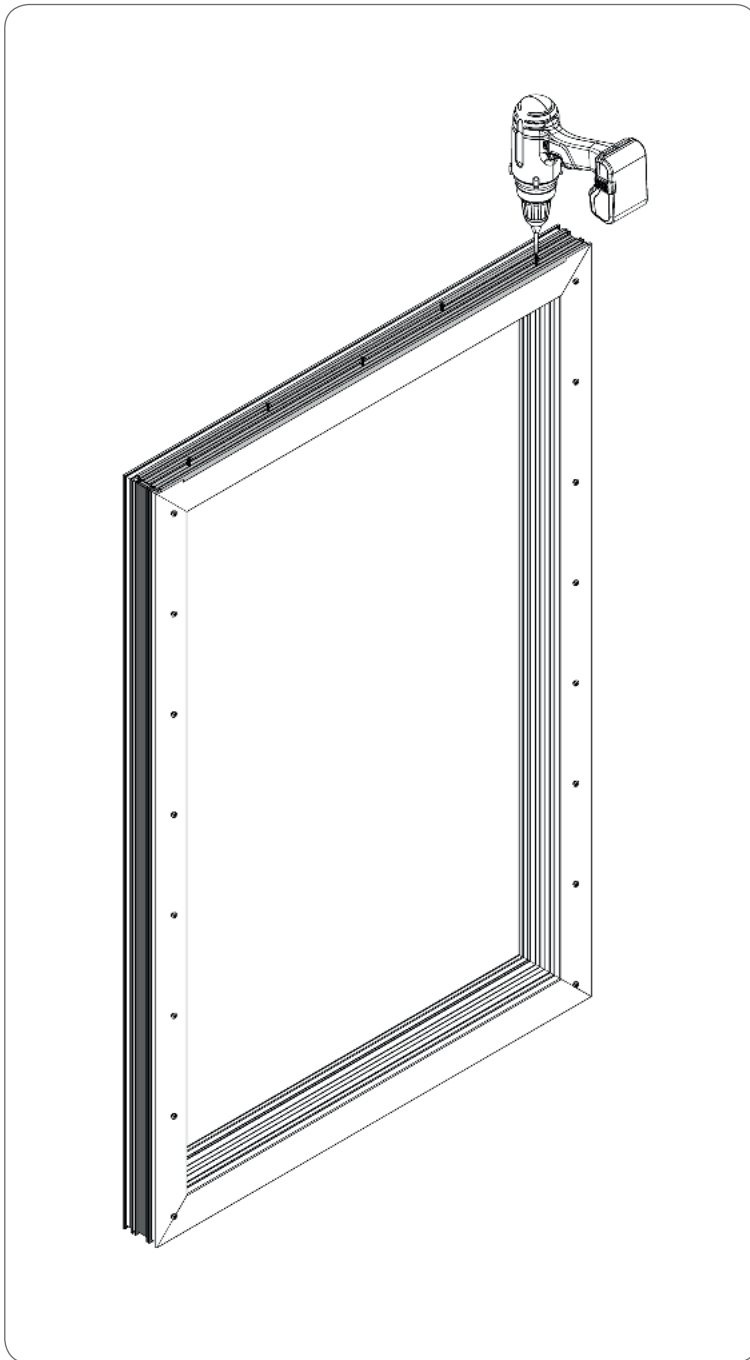

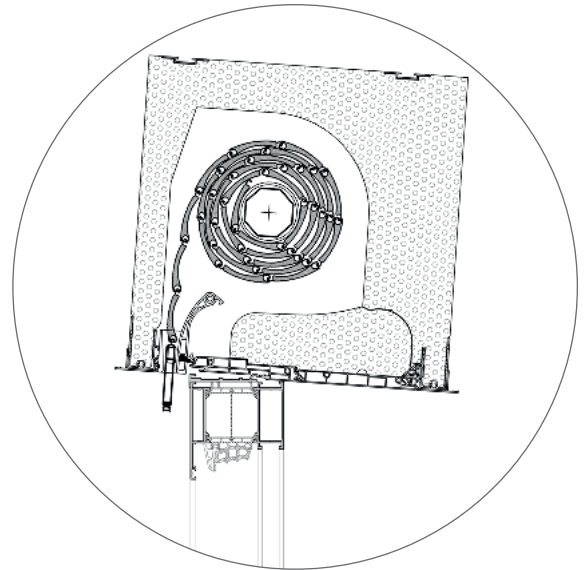
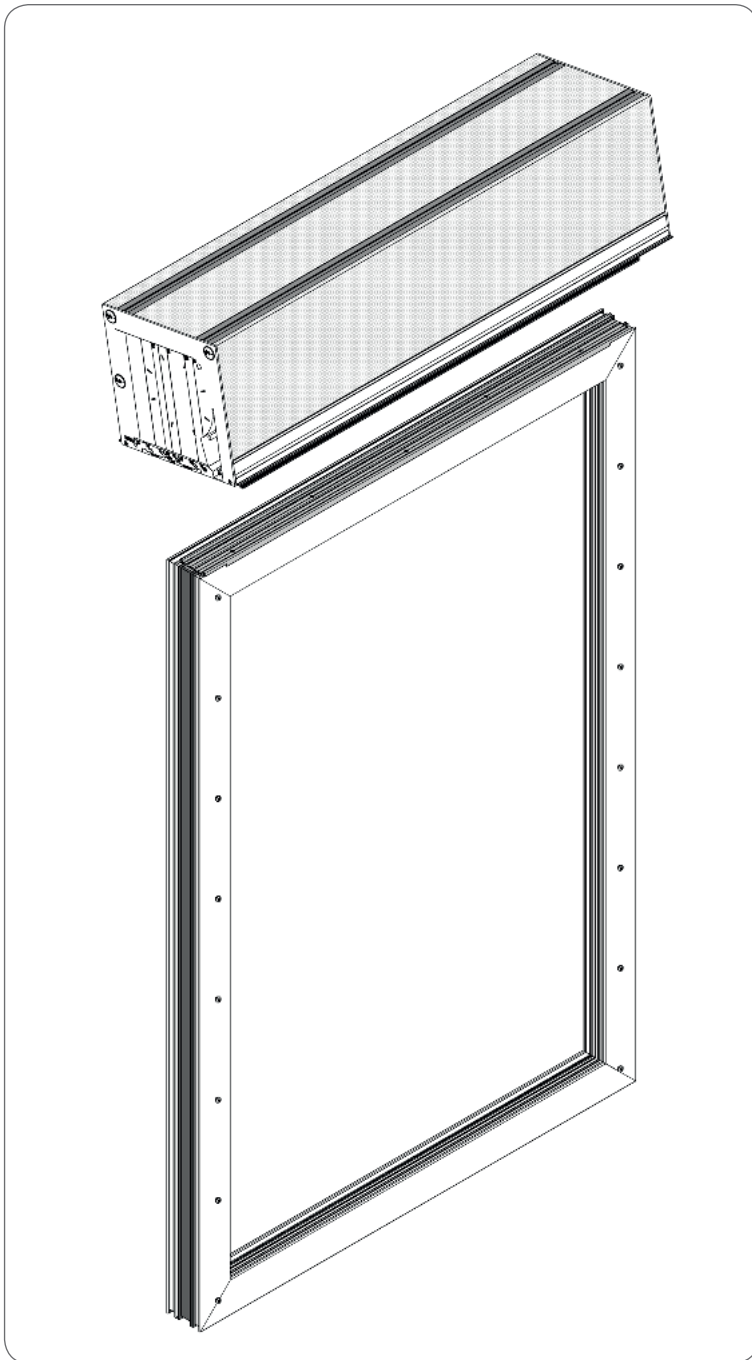

⚠ Die Art und Weise wie man den SKB/RI-Kasten auf das Anpassungsprofil einschiebt

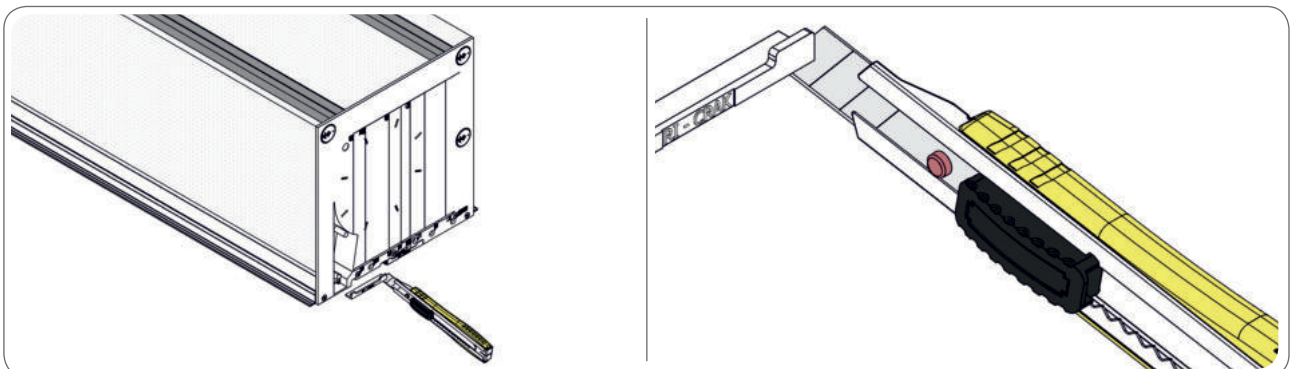
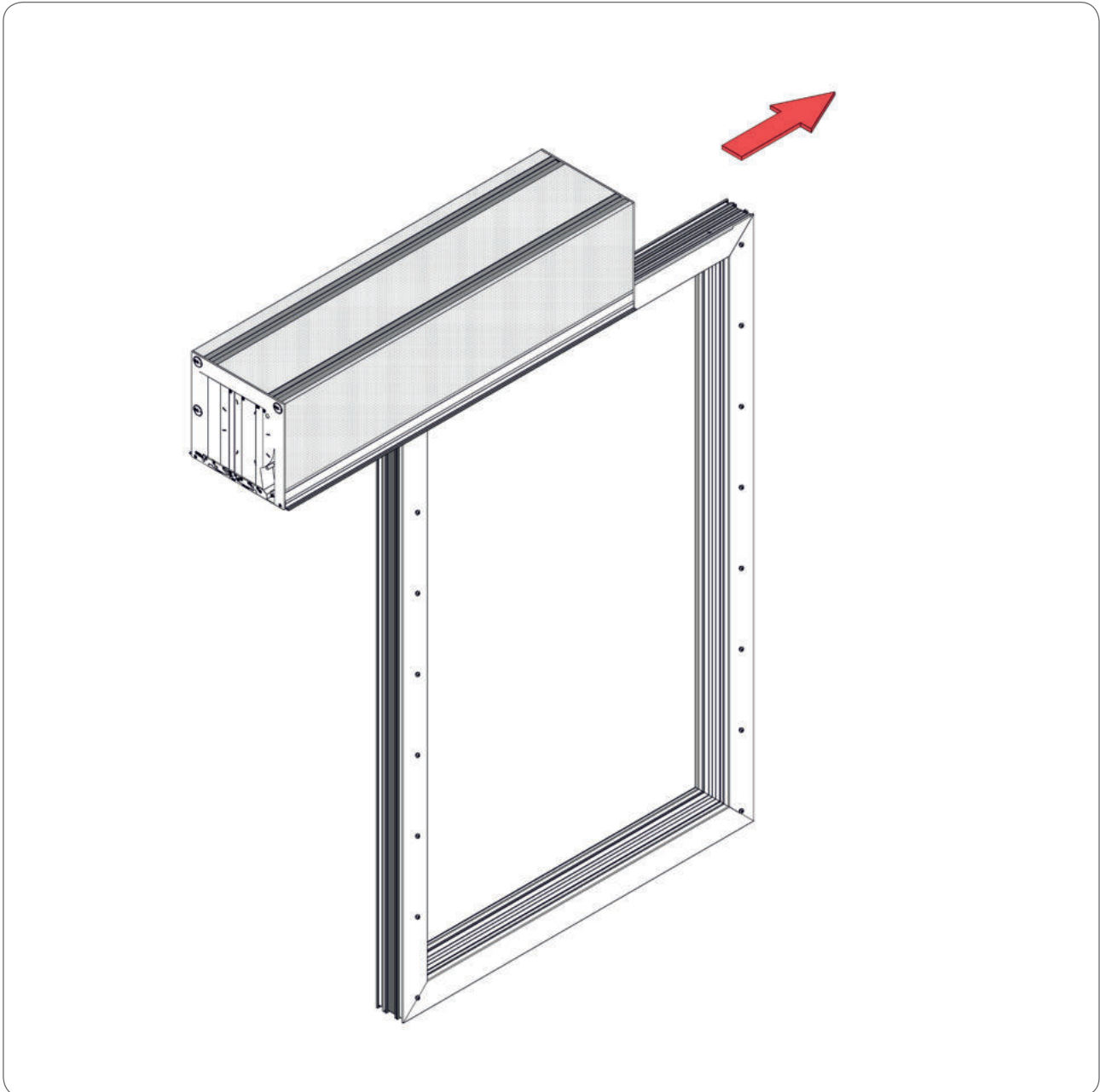

⚠ Die Art und Weise wie man den **SKB/RI + MKT-Kasten** auf das **Anpassungsprofil** einschiebt

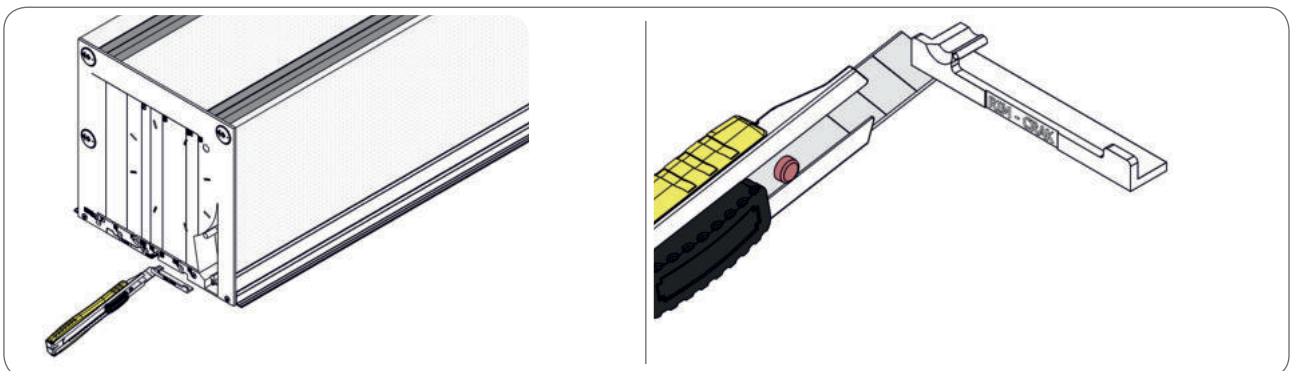
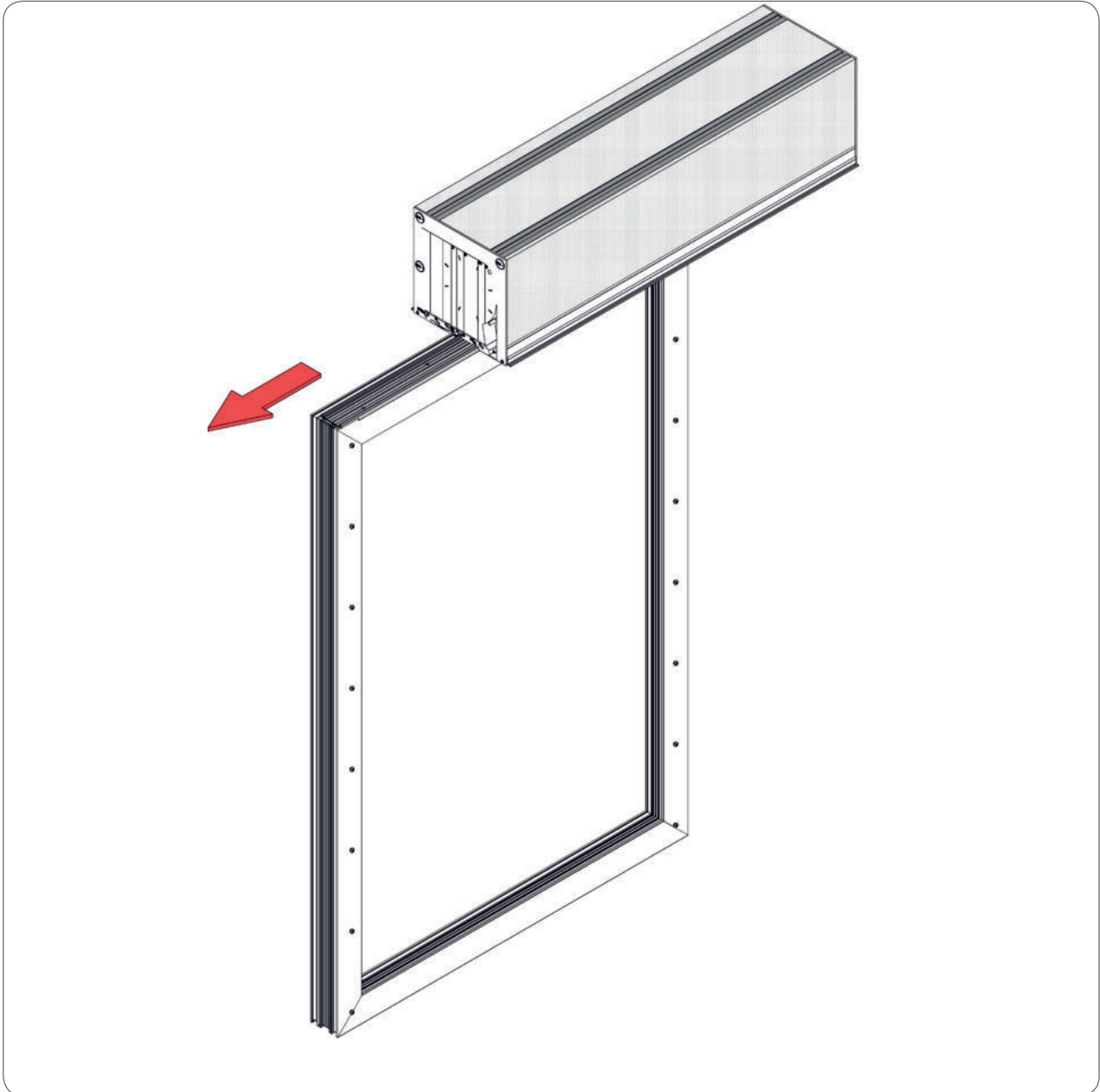

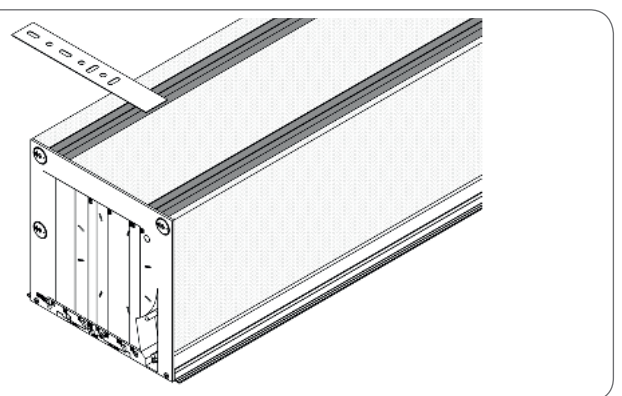
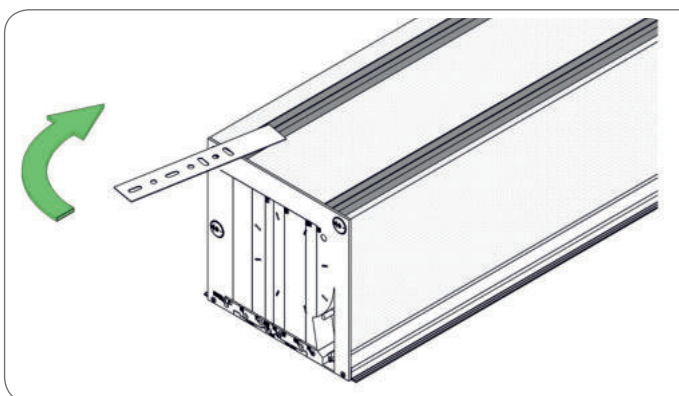
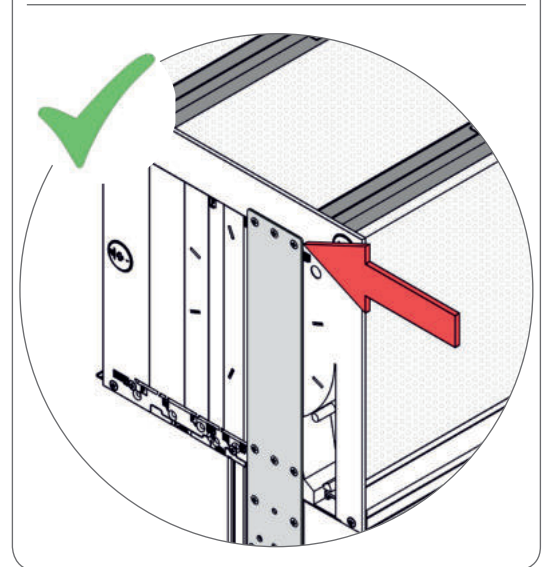
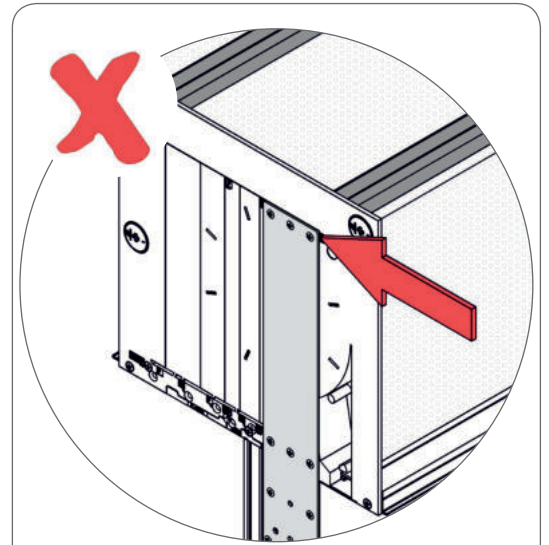
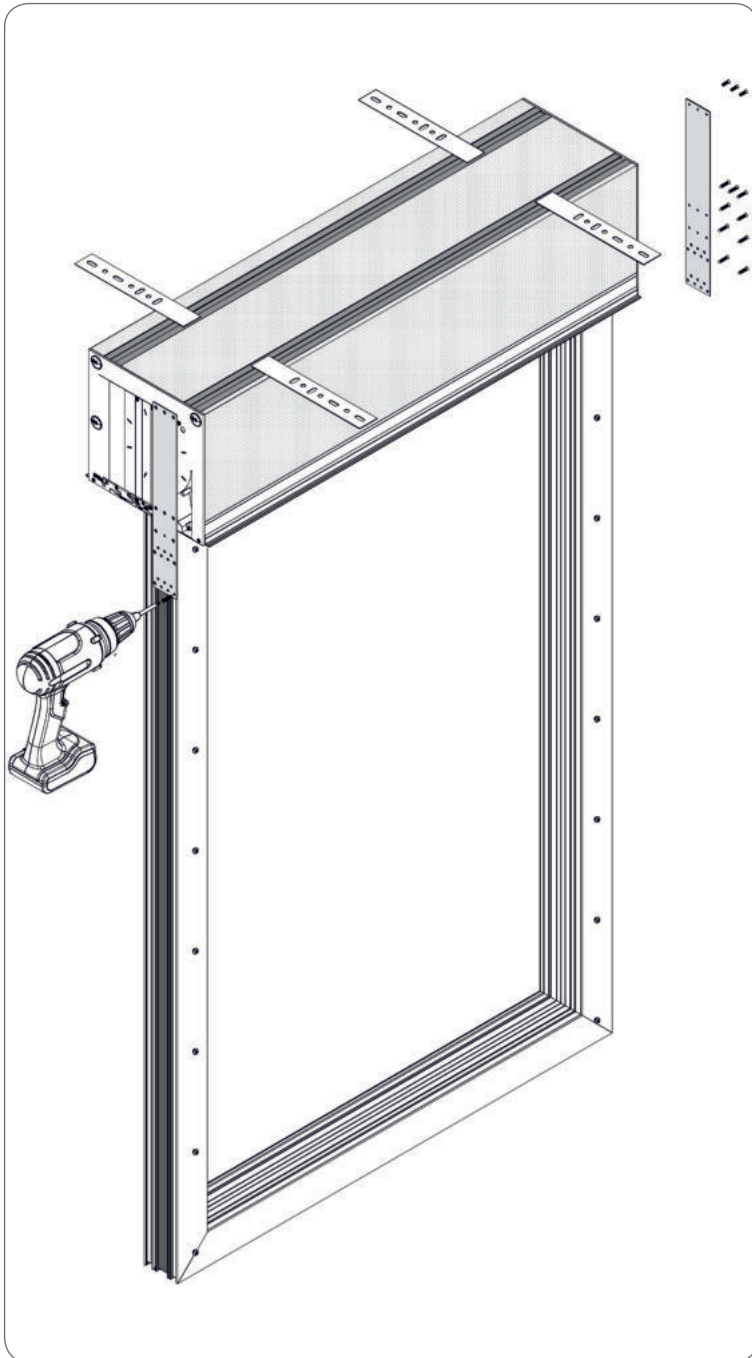

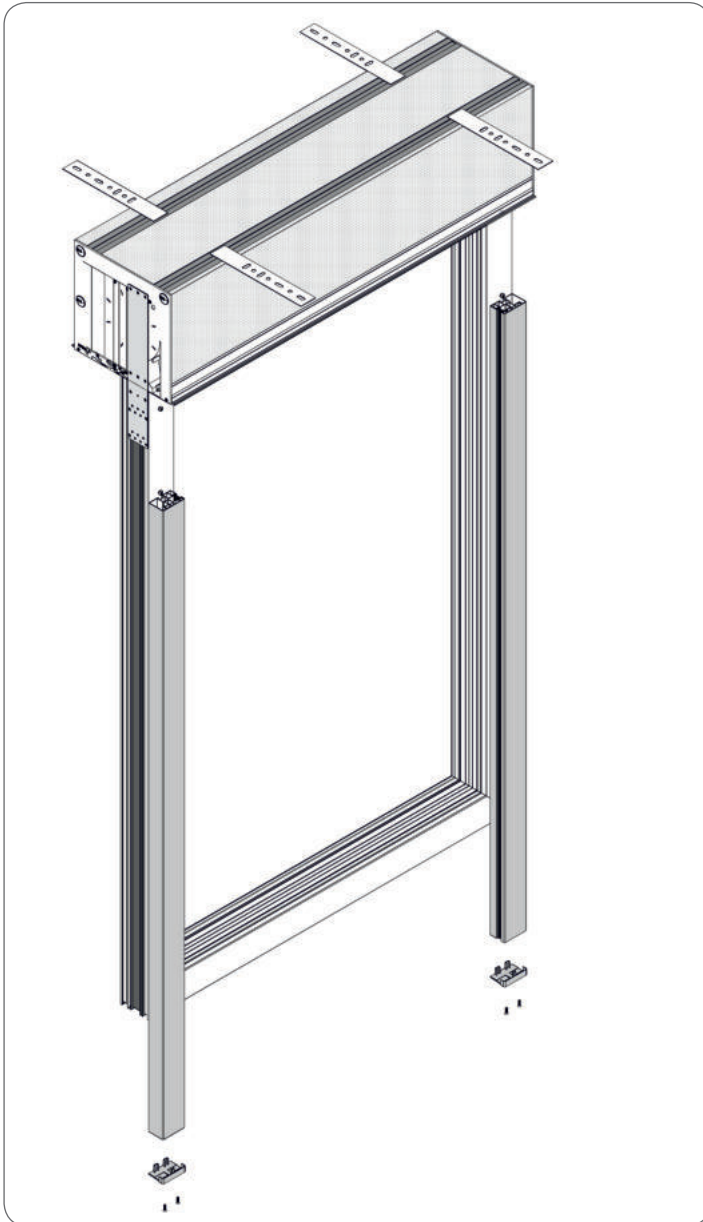

SKB/RI

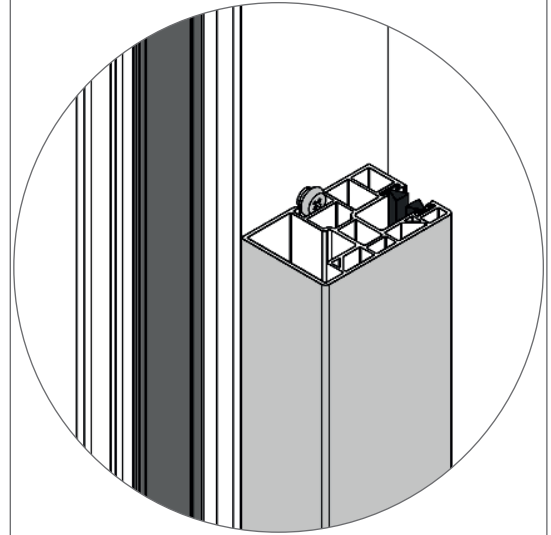

SKB/RI + MKT

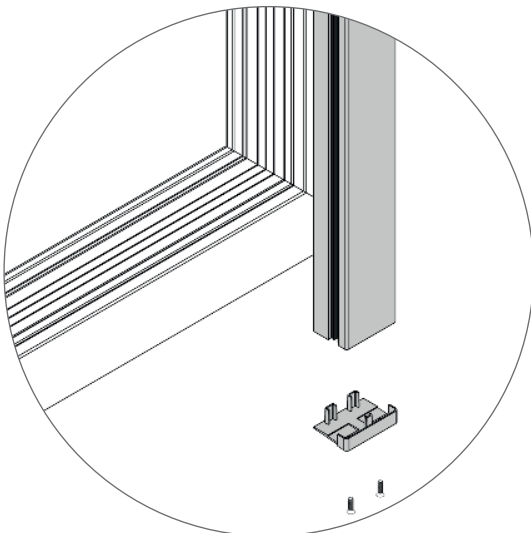
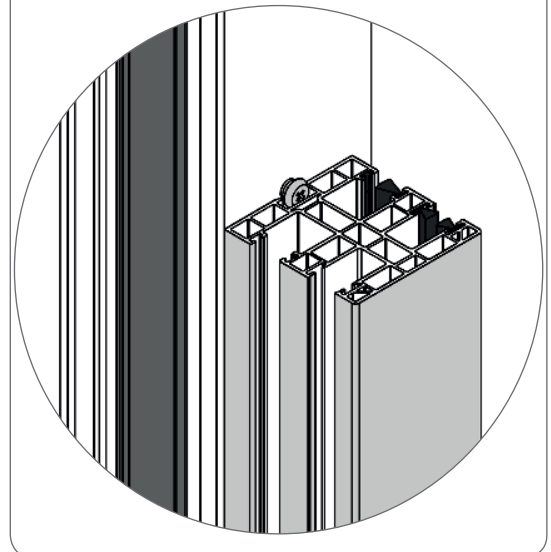

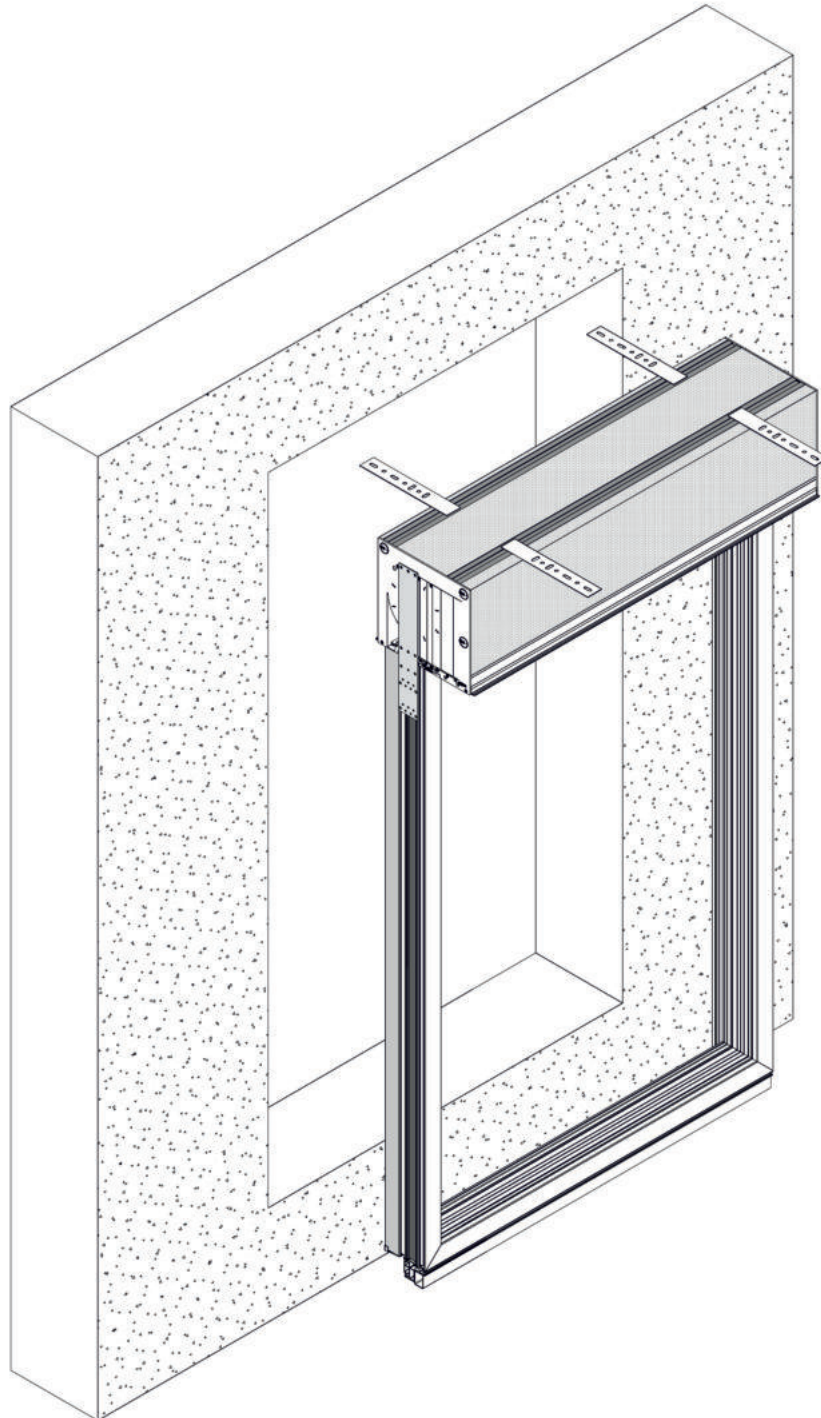

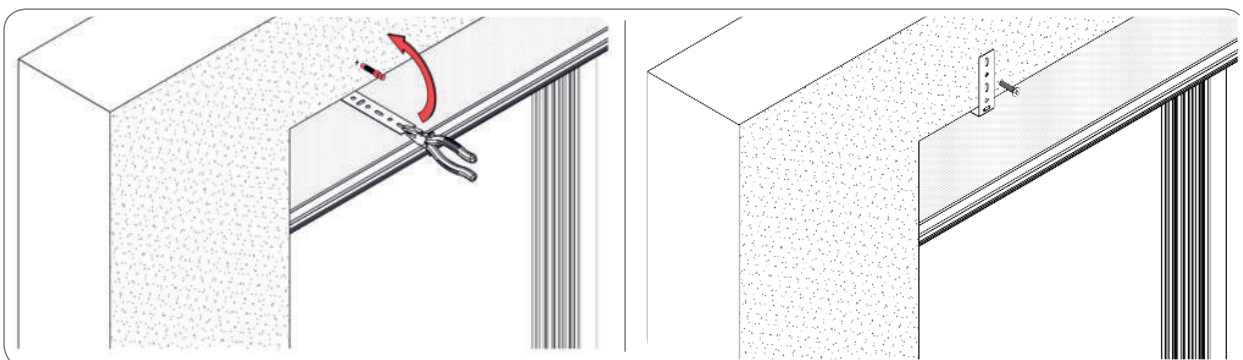
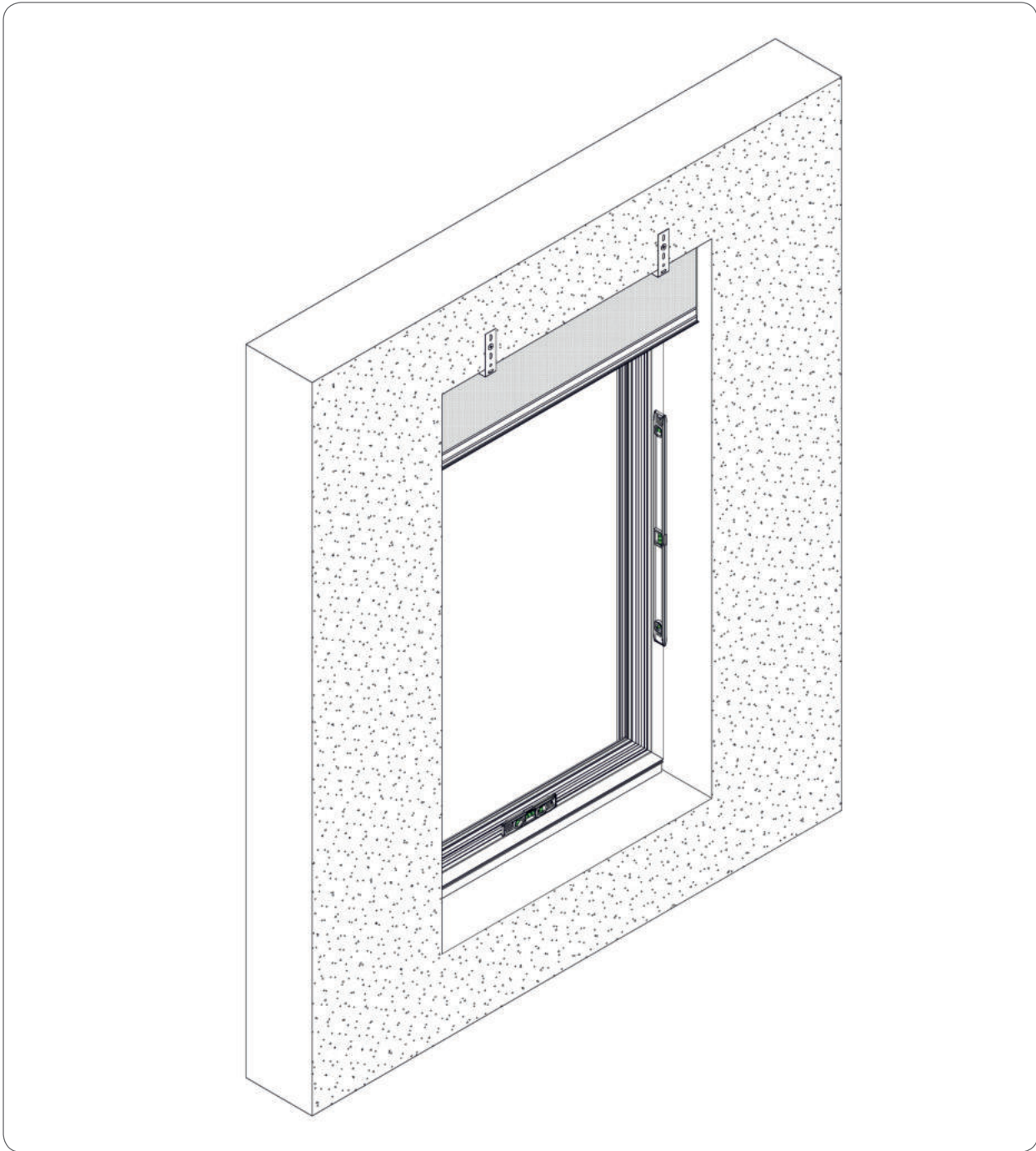

4. DIE REIHENFOLGE DER MONTAGE DES ROLLADENS IM AUFSATZSYSTEM MIT EINER REVISION VON AUSSEN SKB/RA

⚠ Bei Aluminiumfenstern sollten vor der Montage der Nypelschrauben Bohrungen von $\varnothing 2-2,5$ mm gemacht werden.

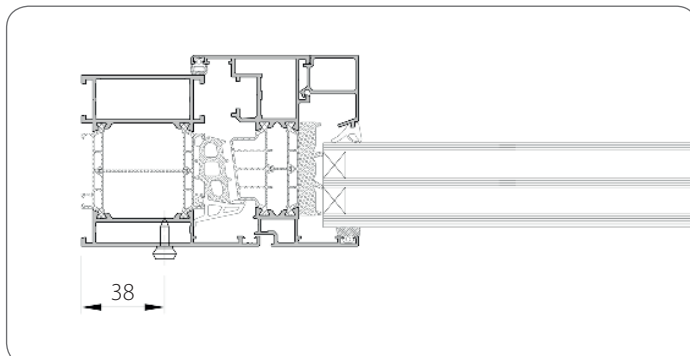
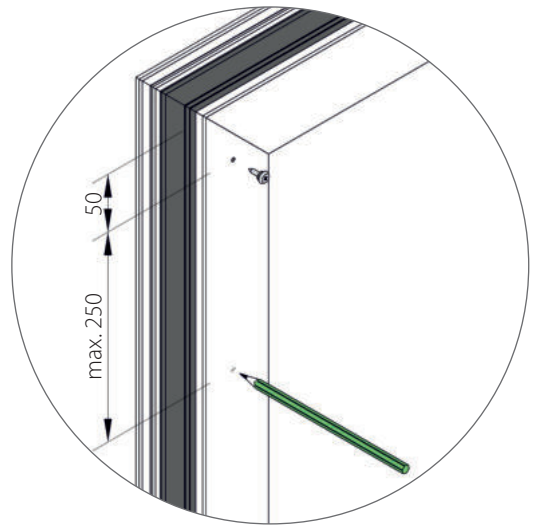
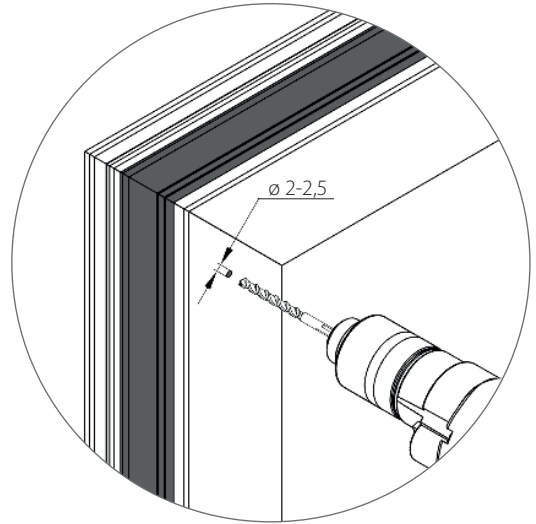
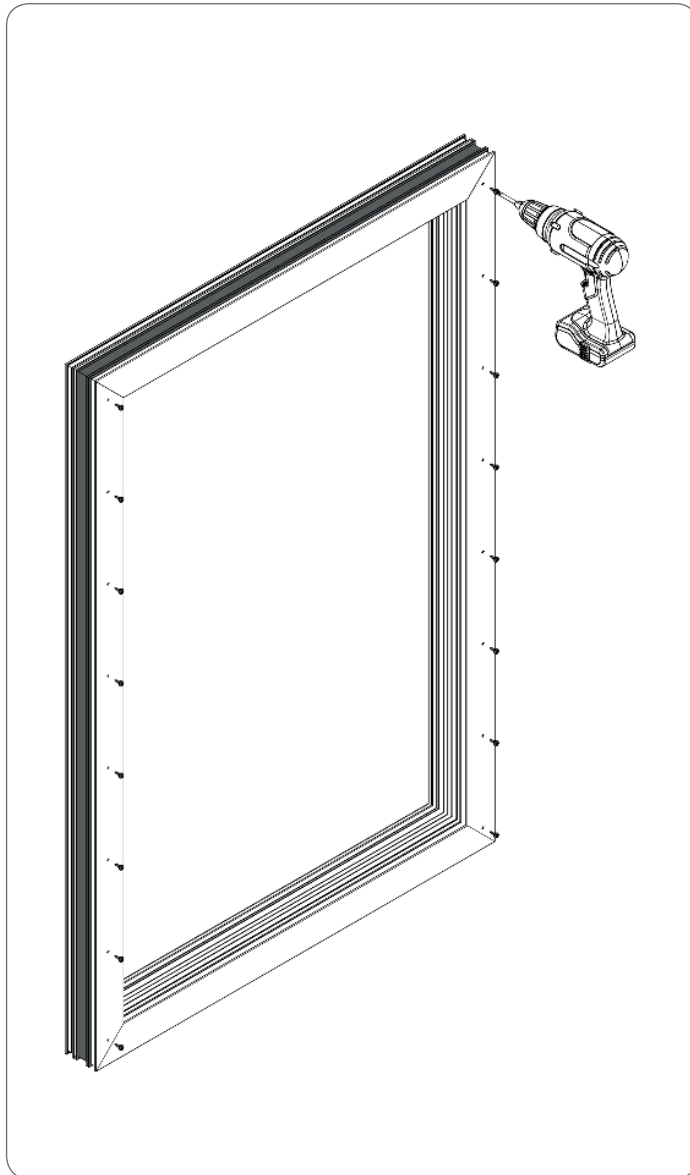

Führungsschienen: **PPRA/12 + APPRA45, PPRA/17 + APPRA45,**
PPMRA/12 + APPRA45, PPMRA/17 + APPRA45

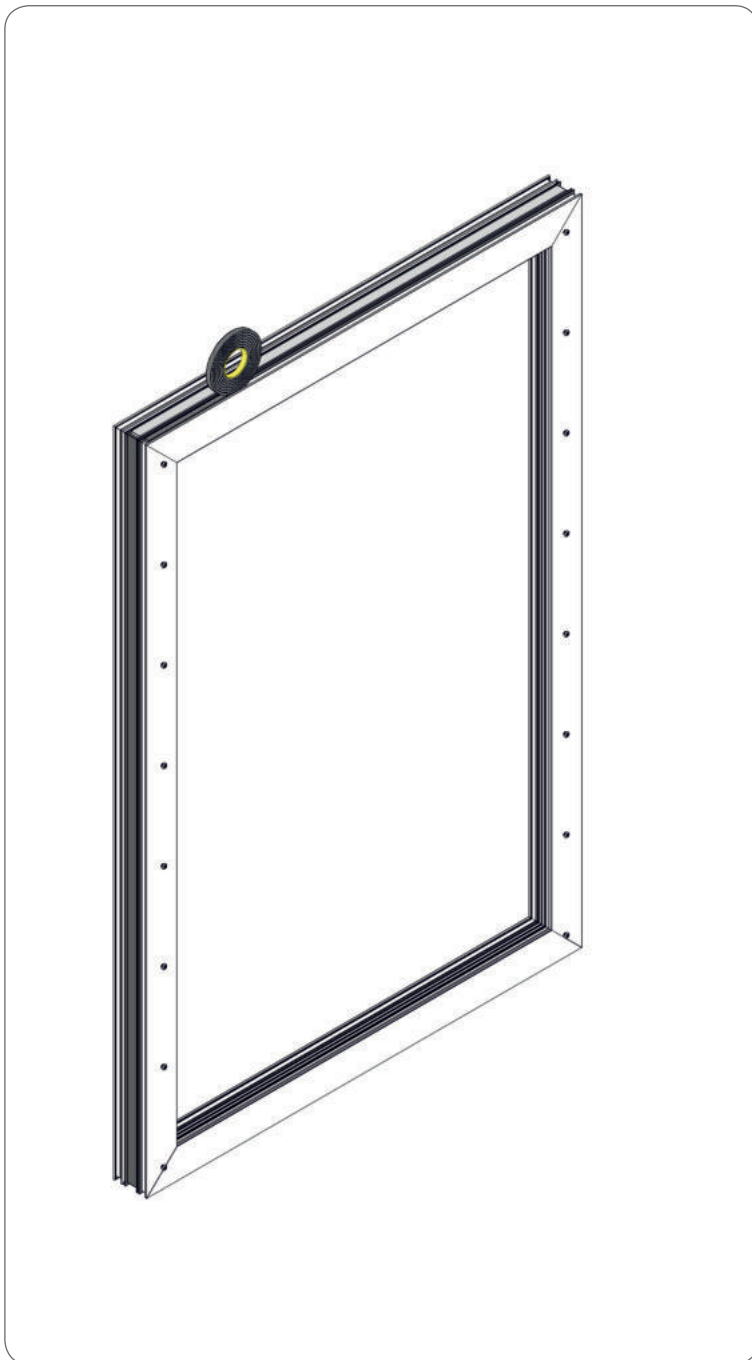

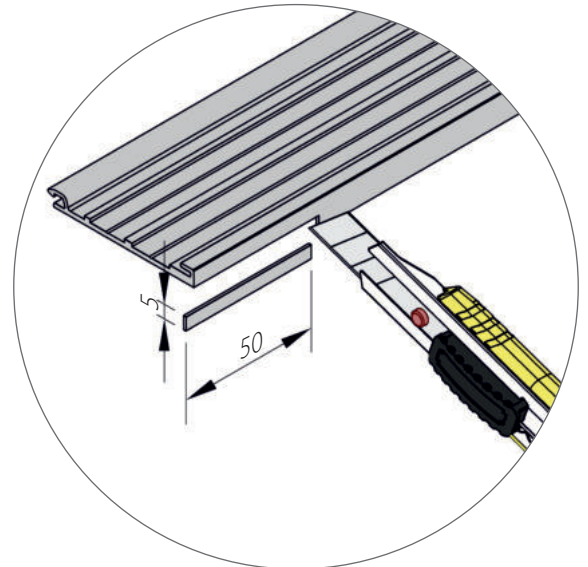
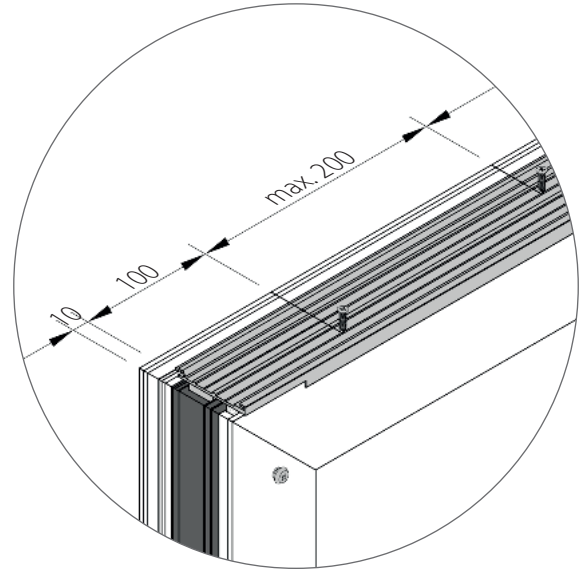
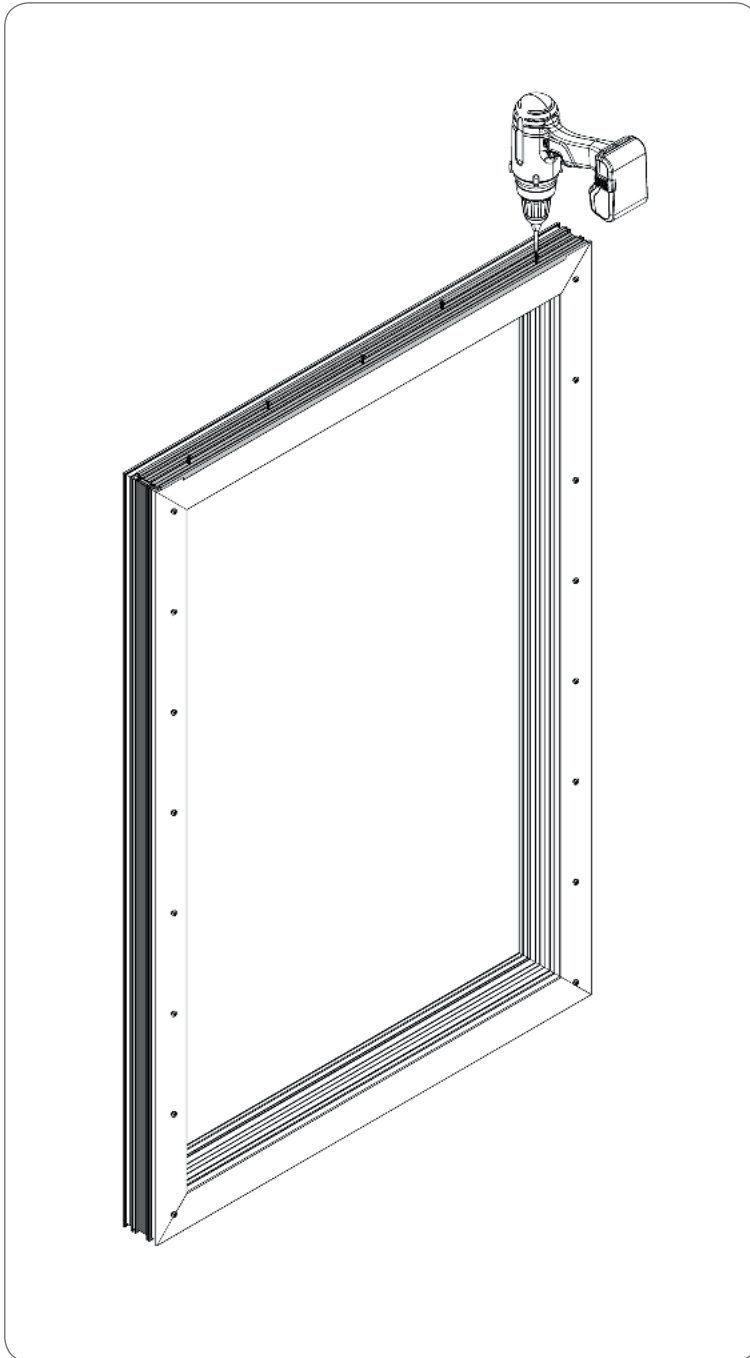

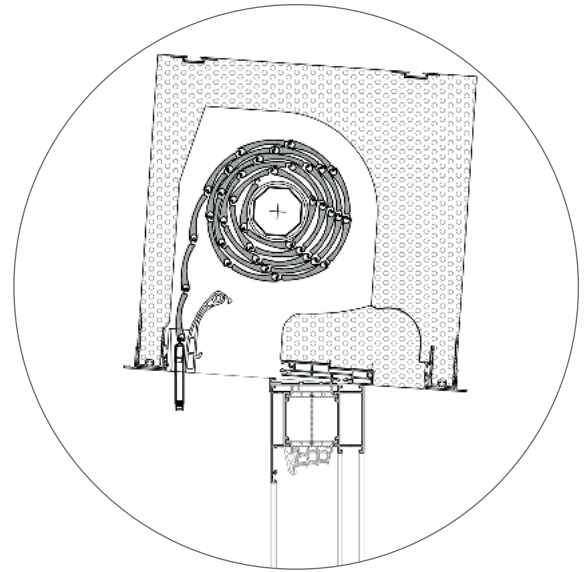

⚠ Die Art und Weise wie man den **SKB/RA** i **SKB/RA + MKT-Kasten** auf das **Anpassungsprofil** einschiebt

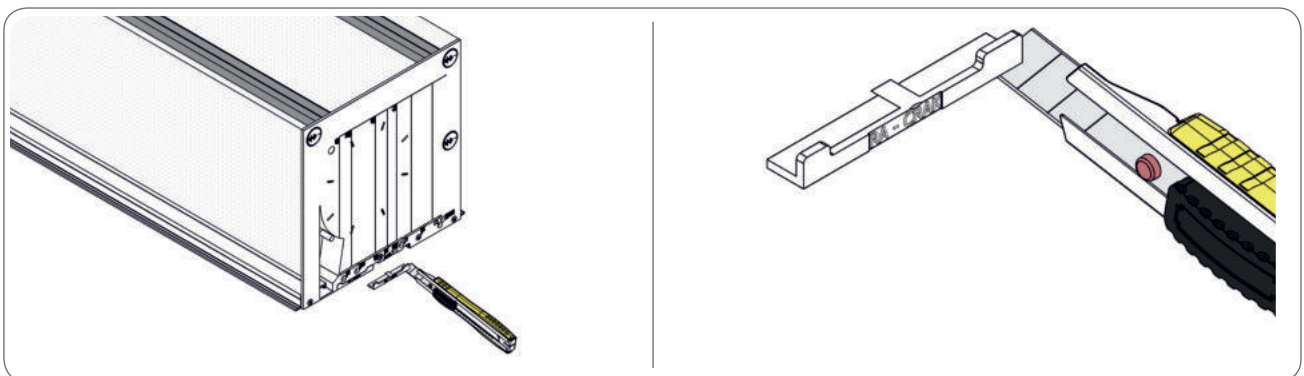
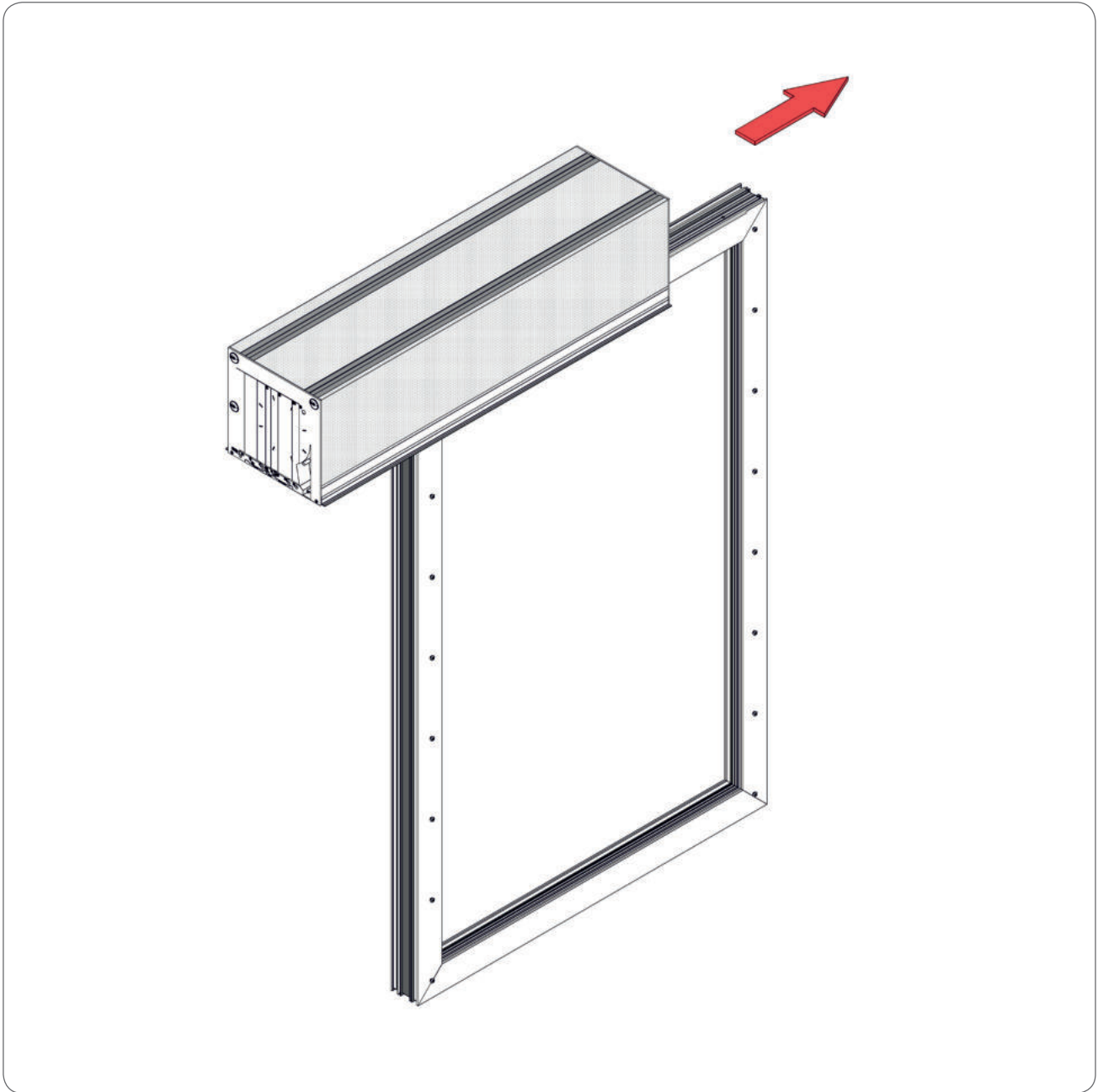

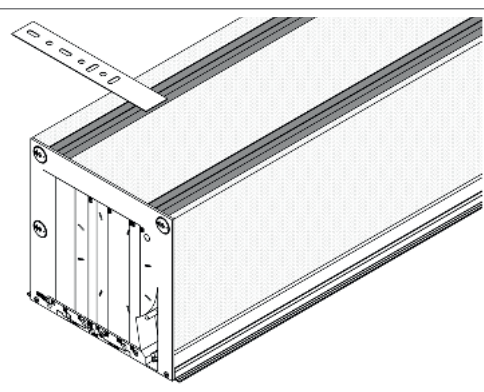
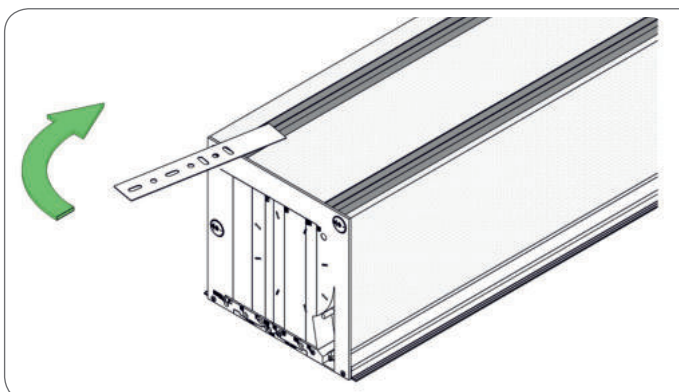
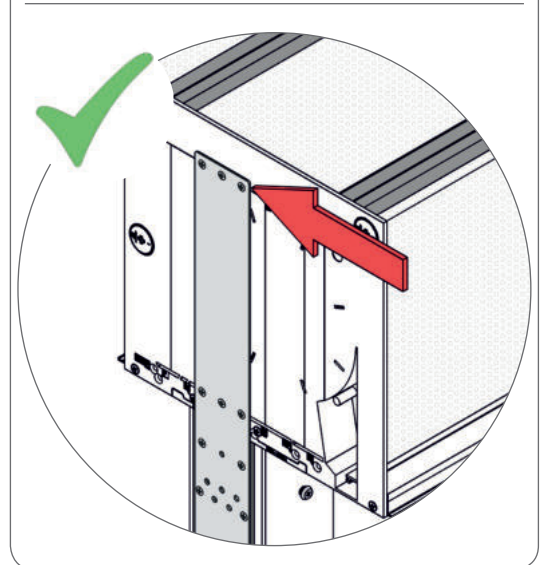
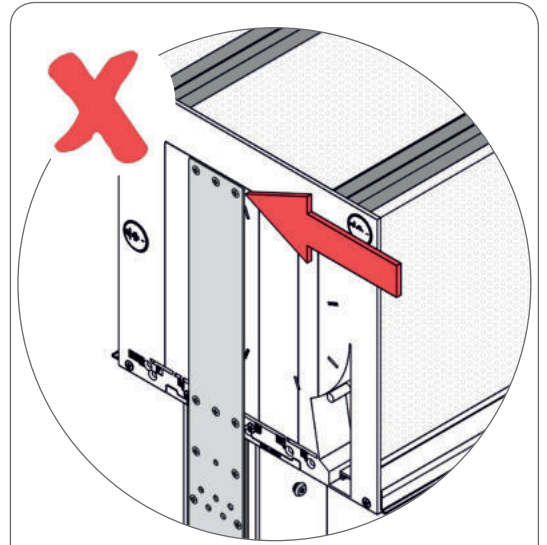
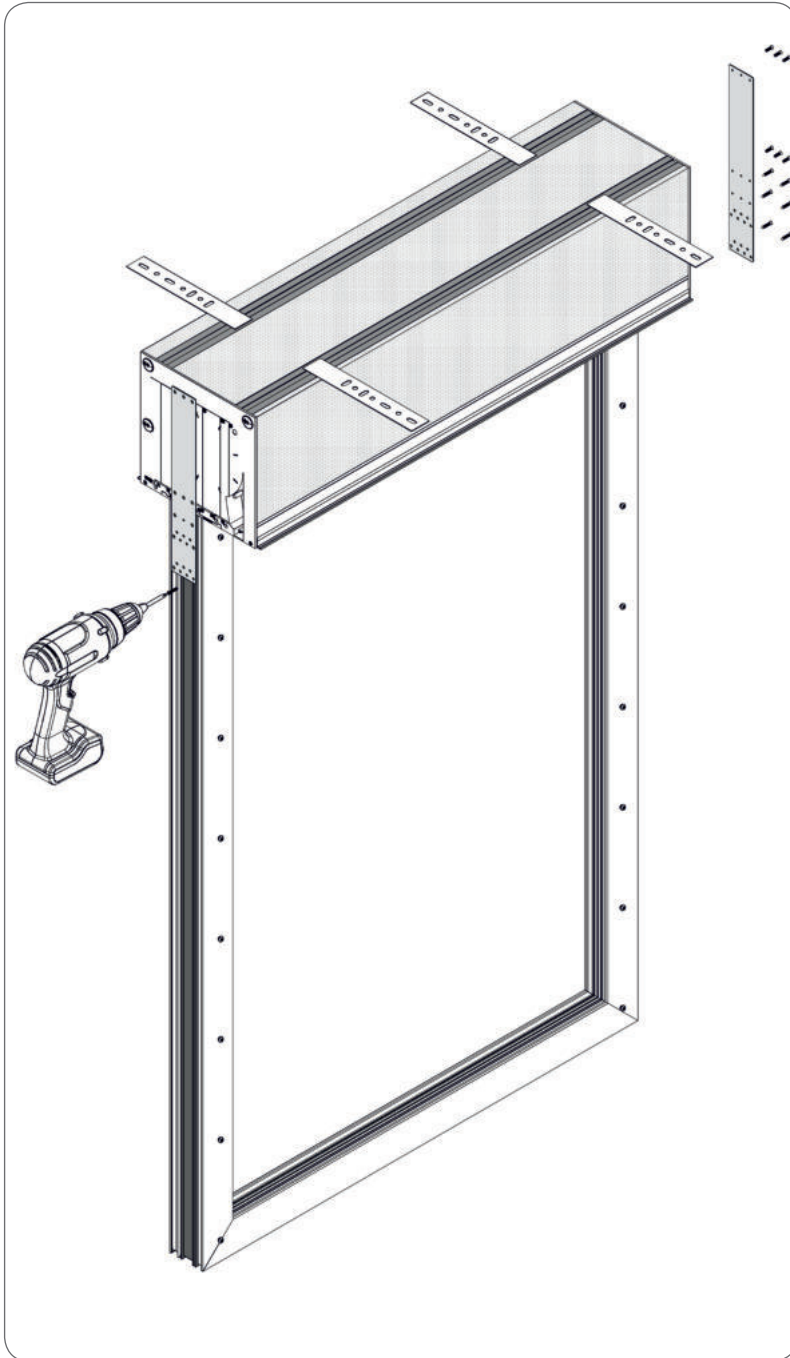

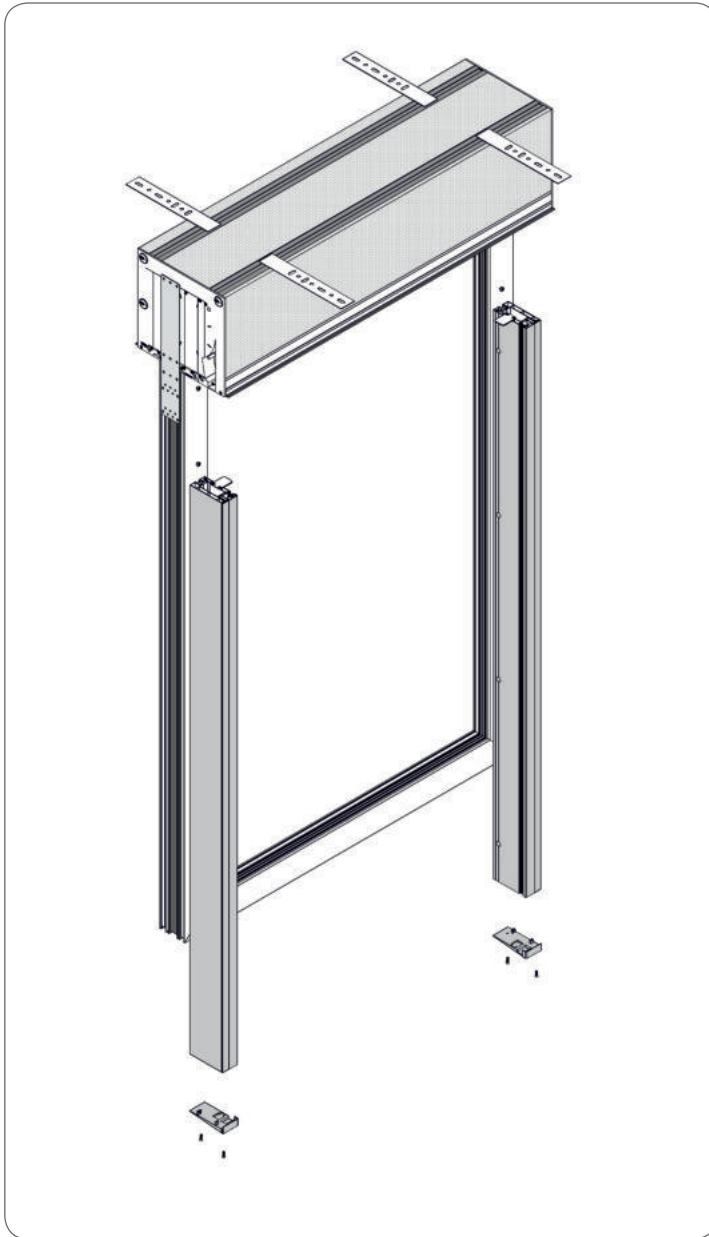

SKB/RA

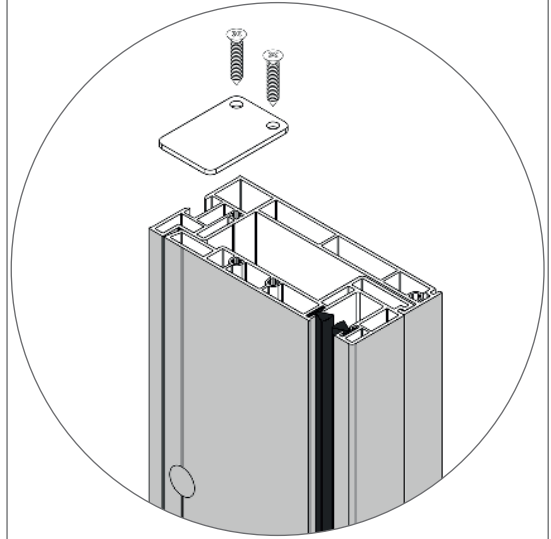

SKB/RA + MKT

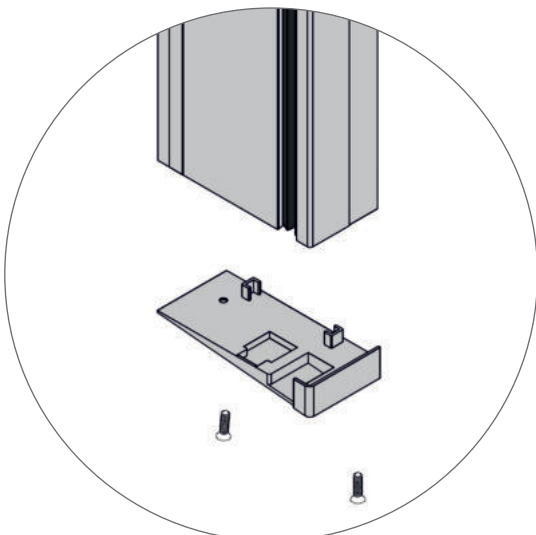
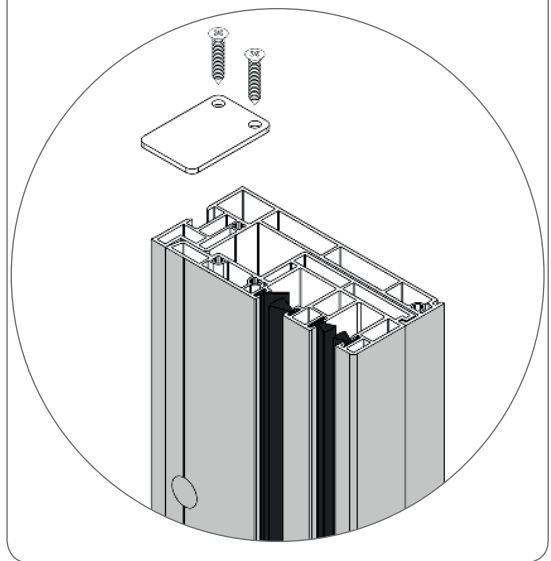

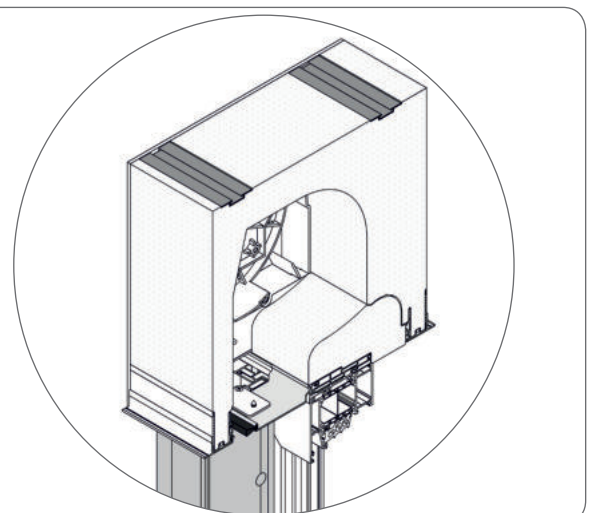
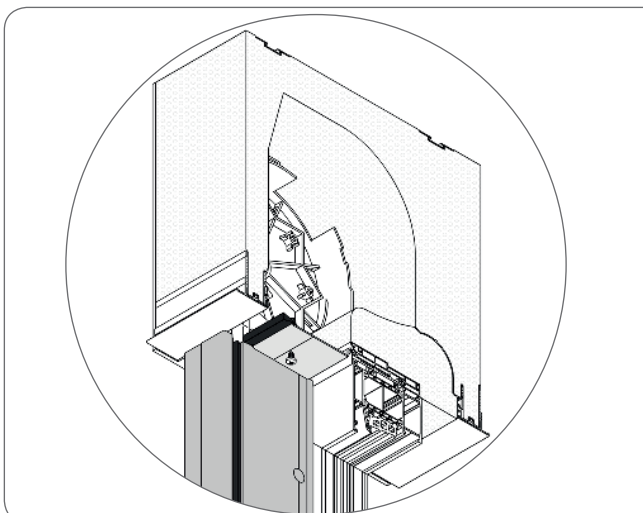
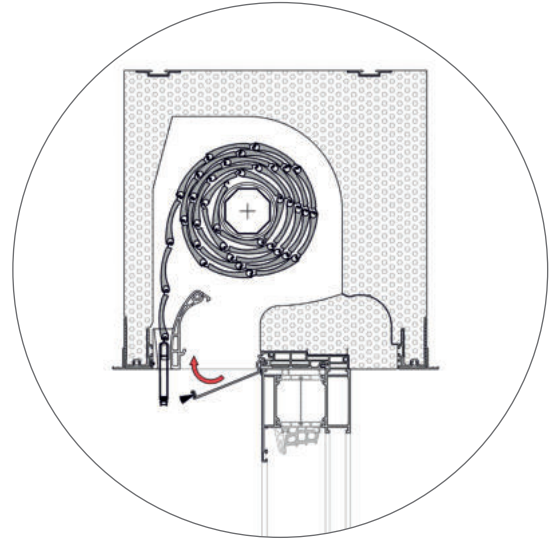
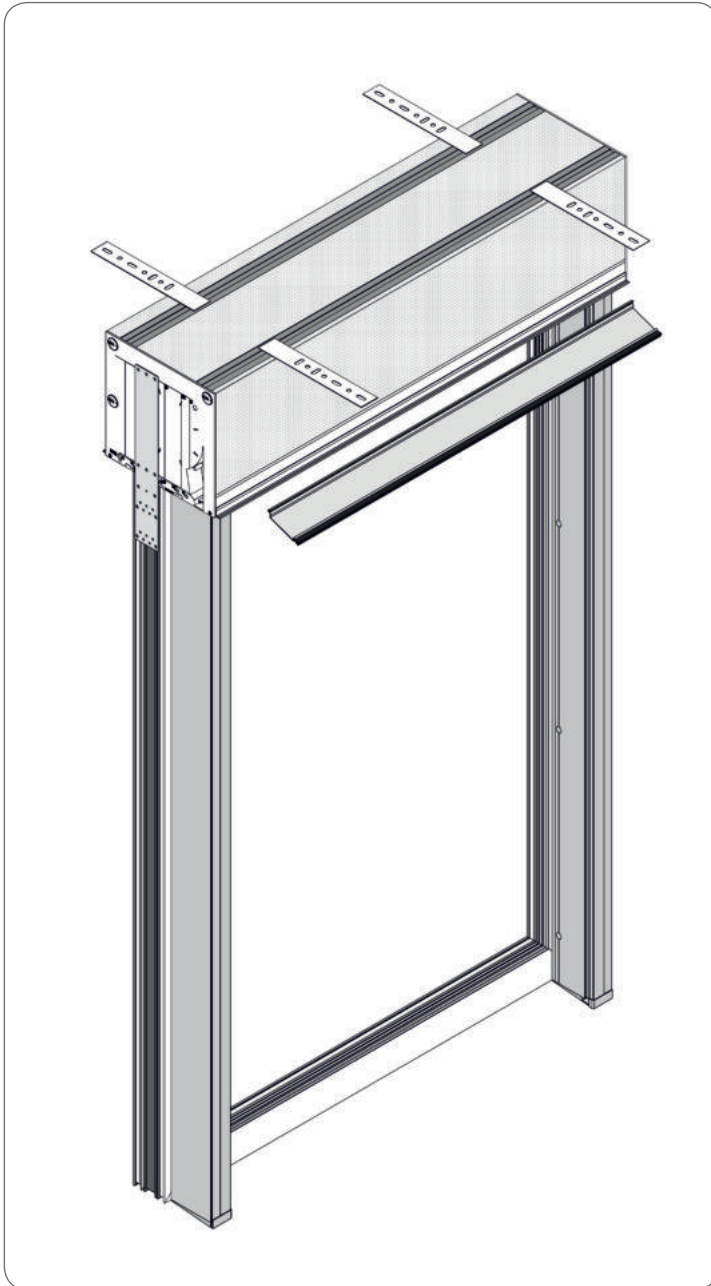

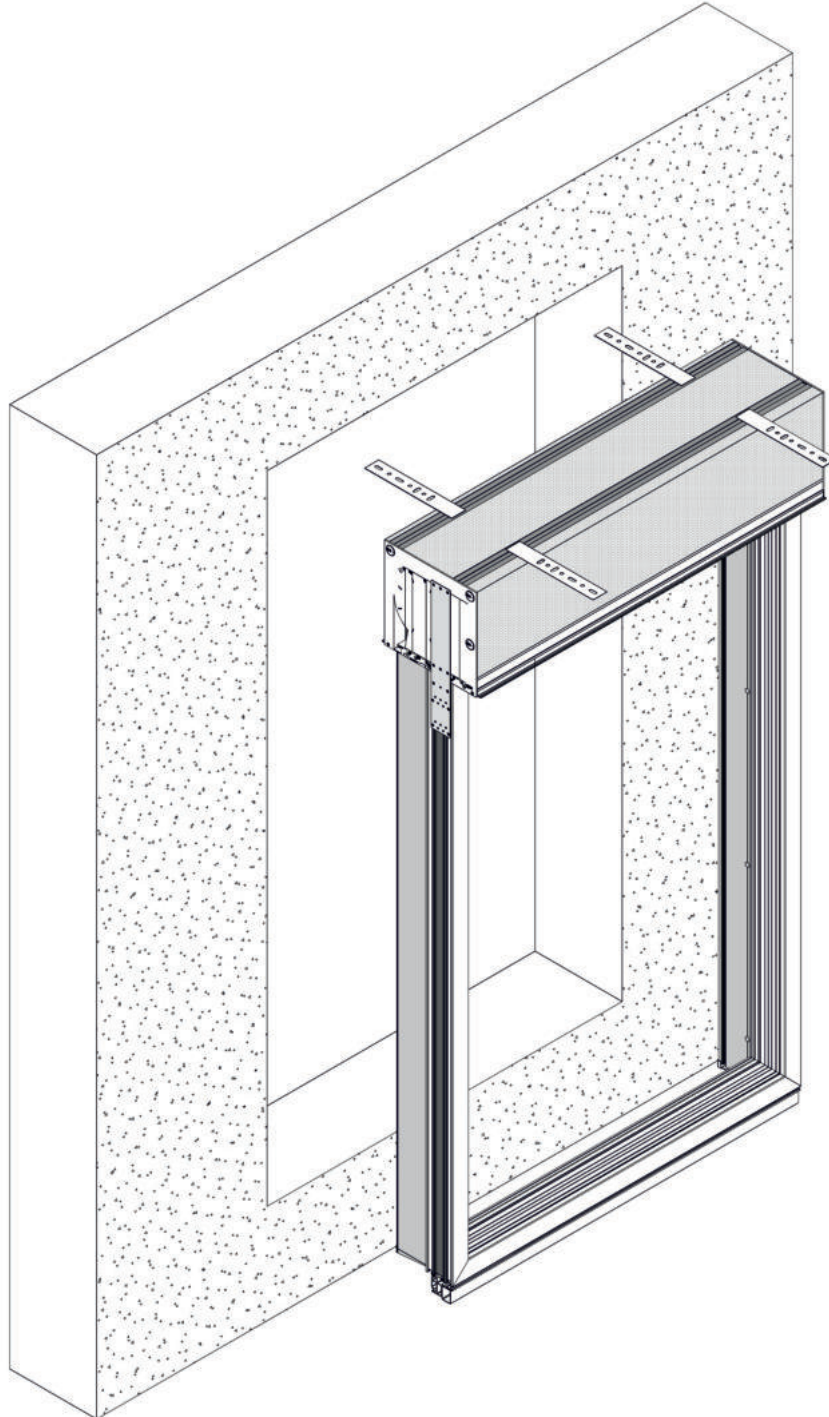

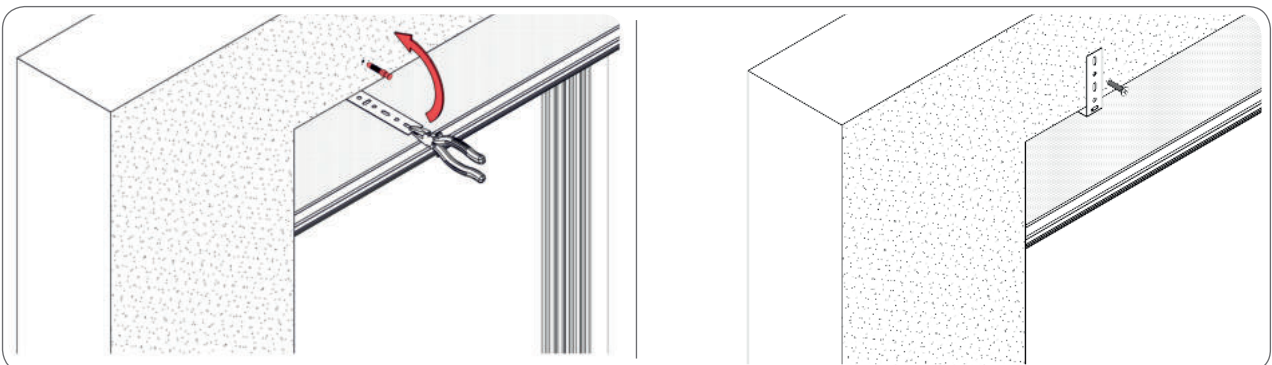
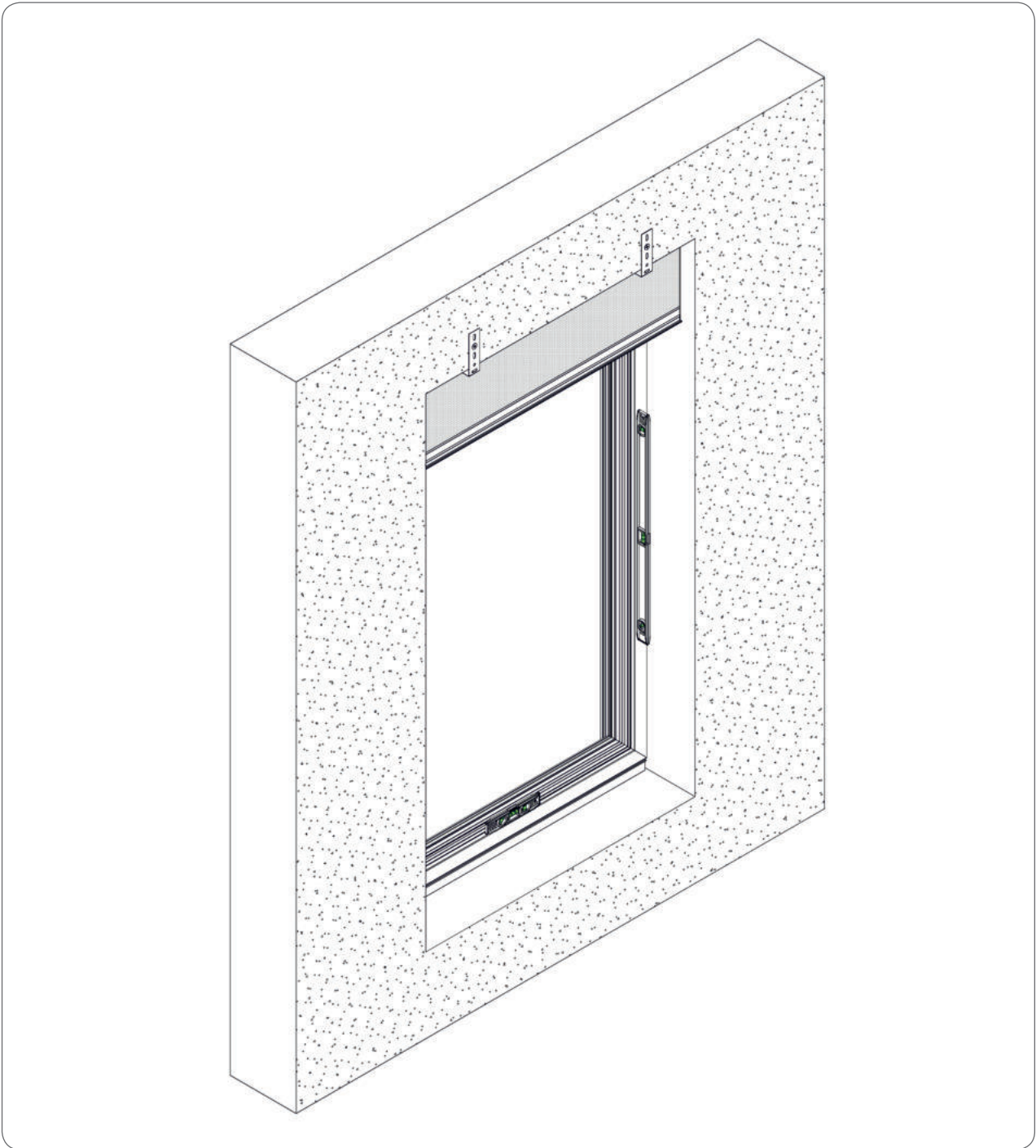

5. DIE REINFOLGE DER MONTAGE DER FASSADENJALOUSIE IM AUFSATZSYSTEM SKB/F

⚠ Bei Aluminiumfenstern sollten vor der Montage der Nypelschrauben Bohrungen von $\varnothing 2-2,5$ mm gemacht werden.

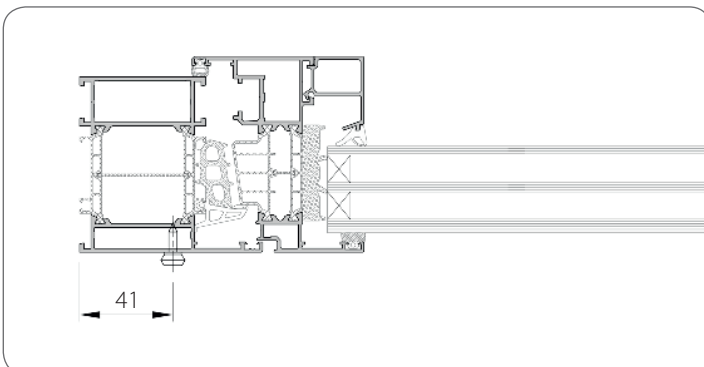
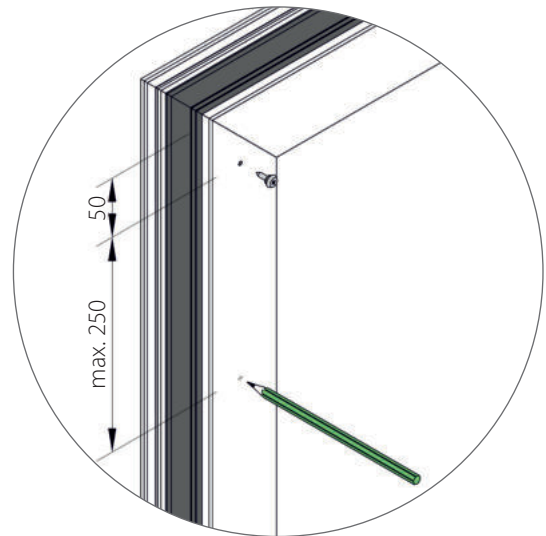
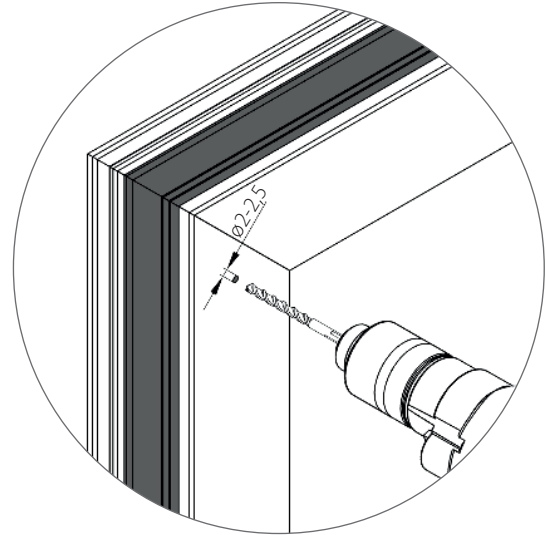
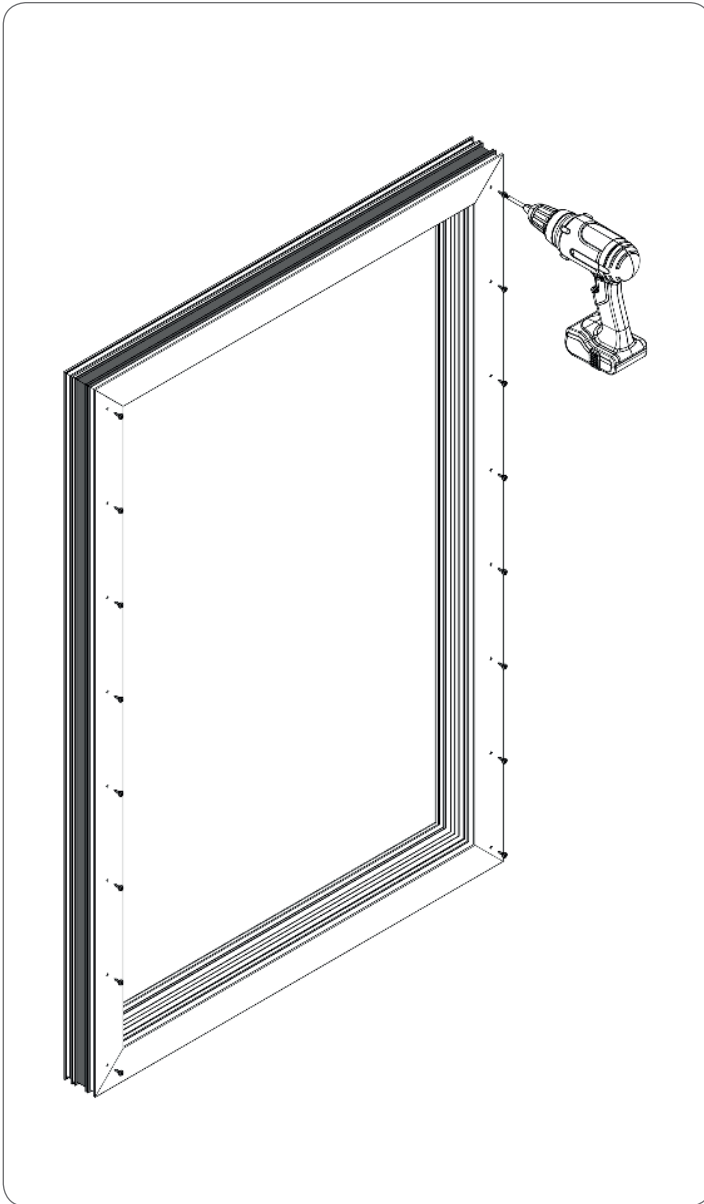

Führungsschienen: **PPF + APPF/B33,**
PPF + APPF/B33 + PPZ32MZN

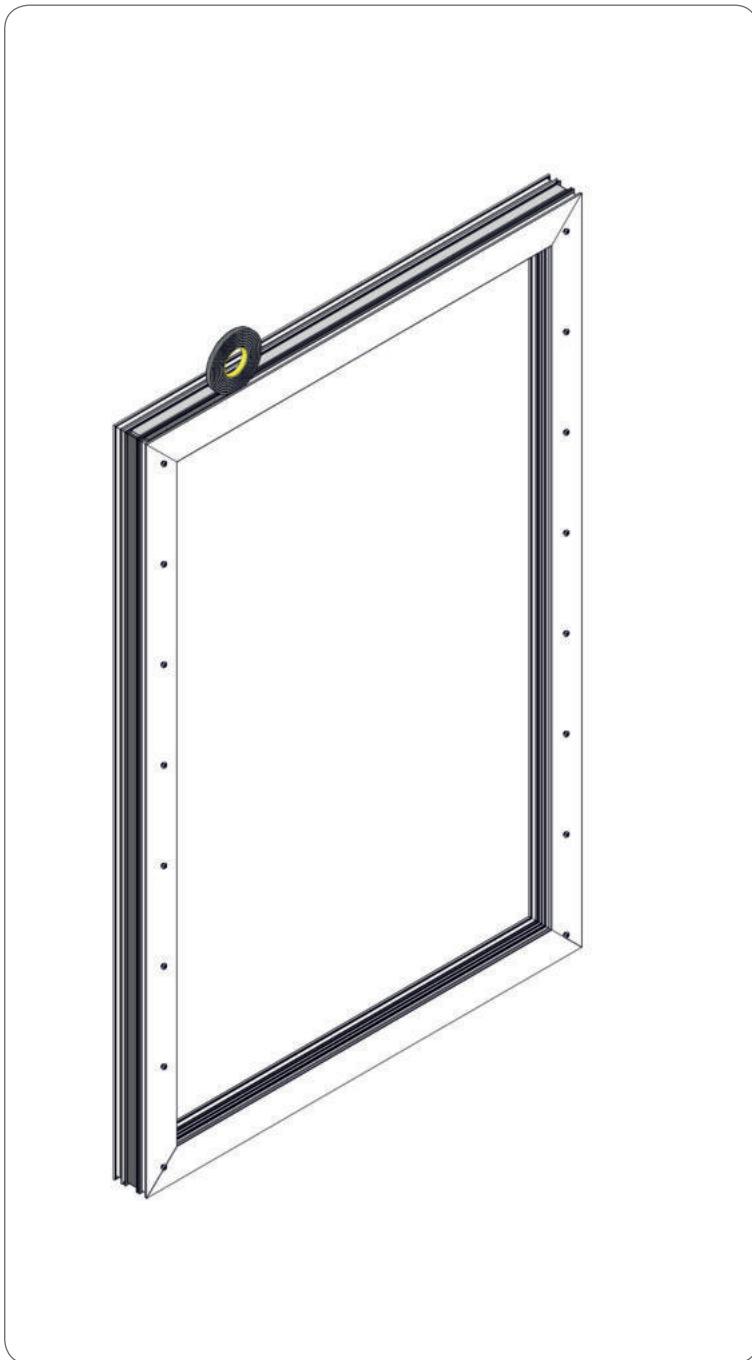

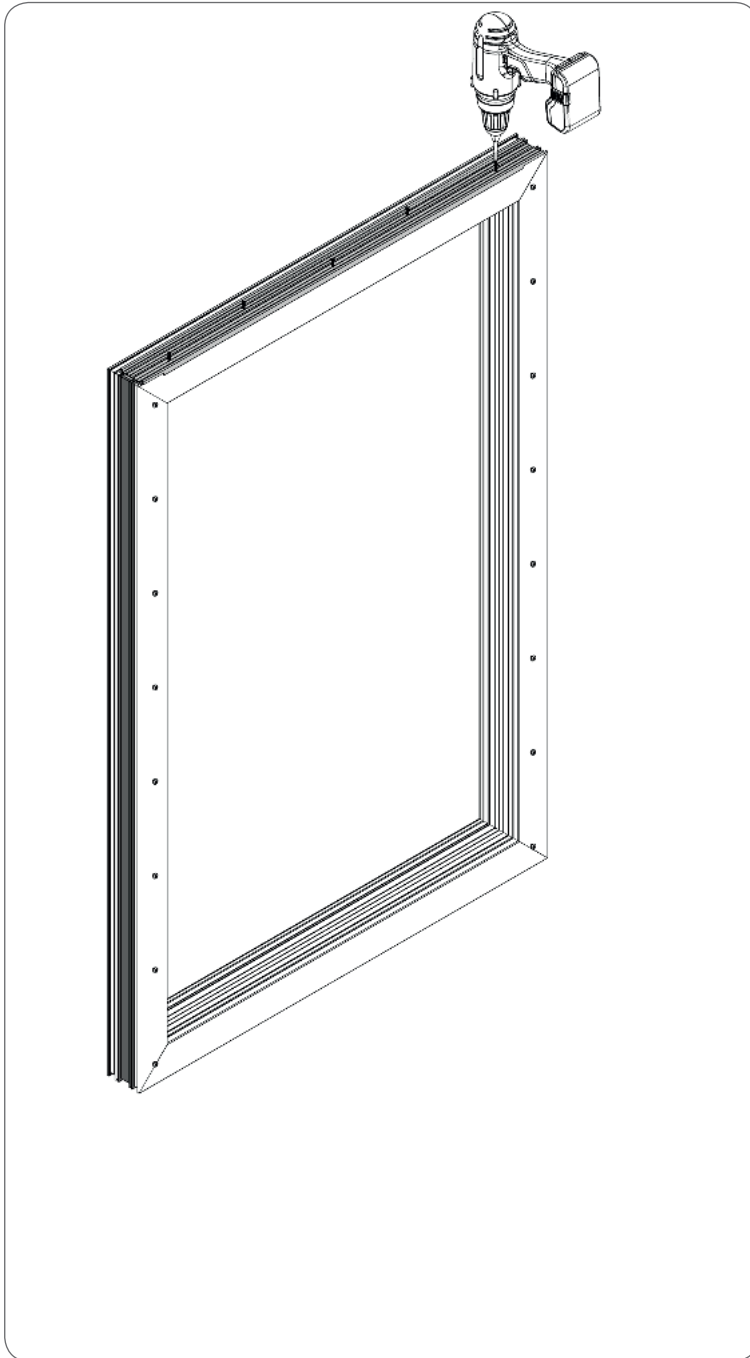

SKB/F

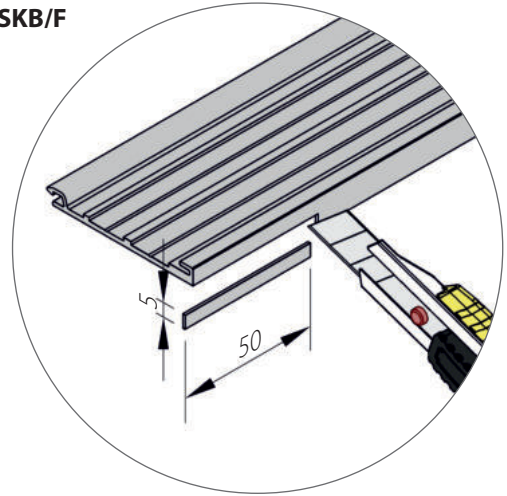

SKB/F + MKT

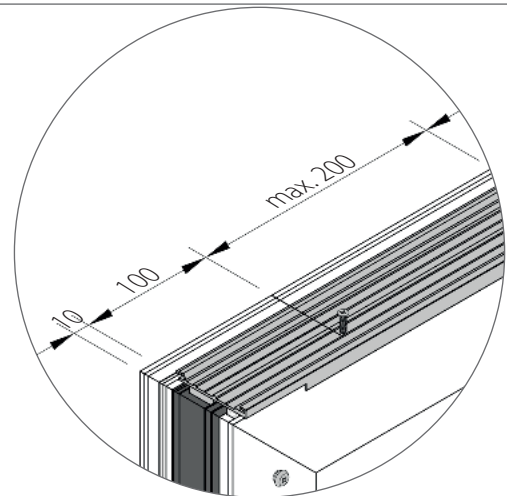
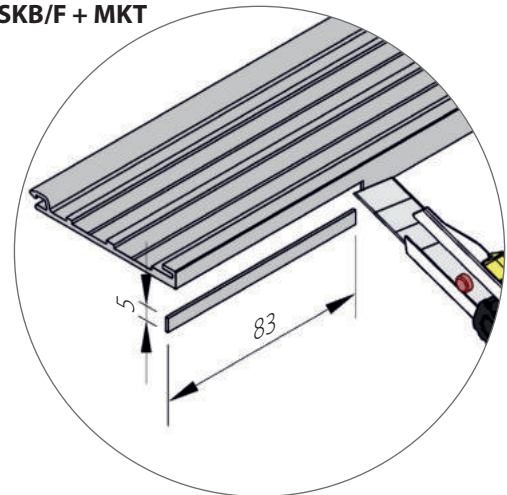

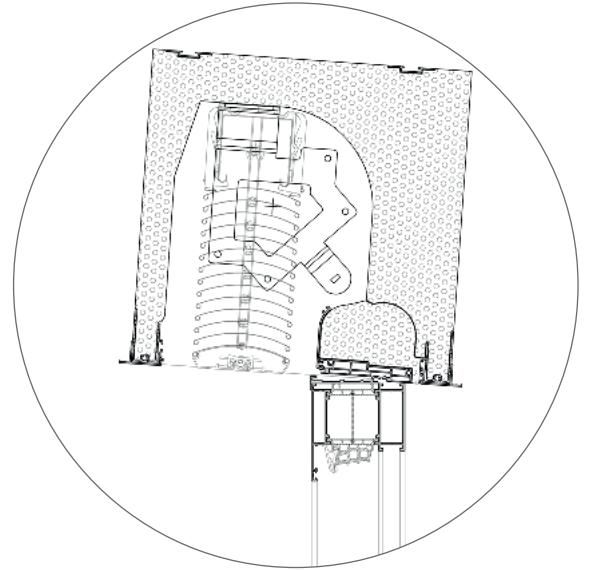
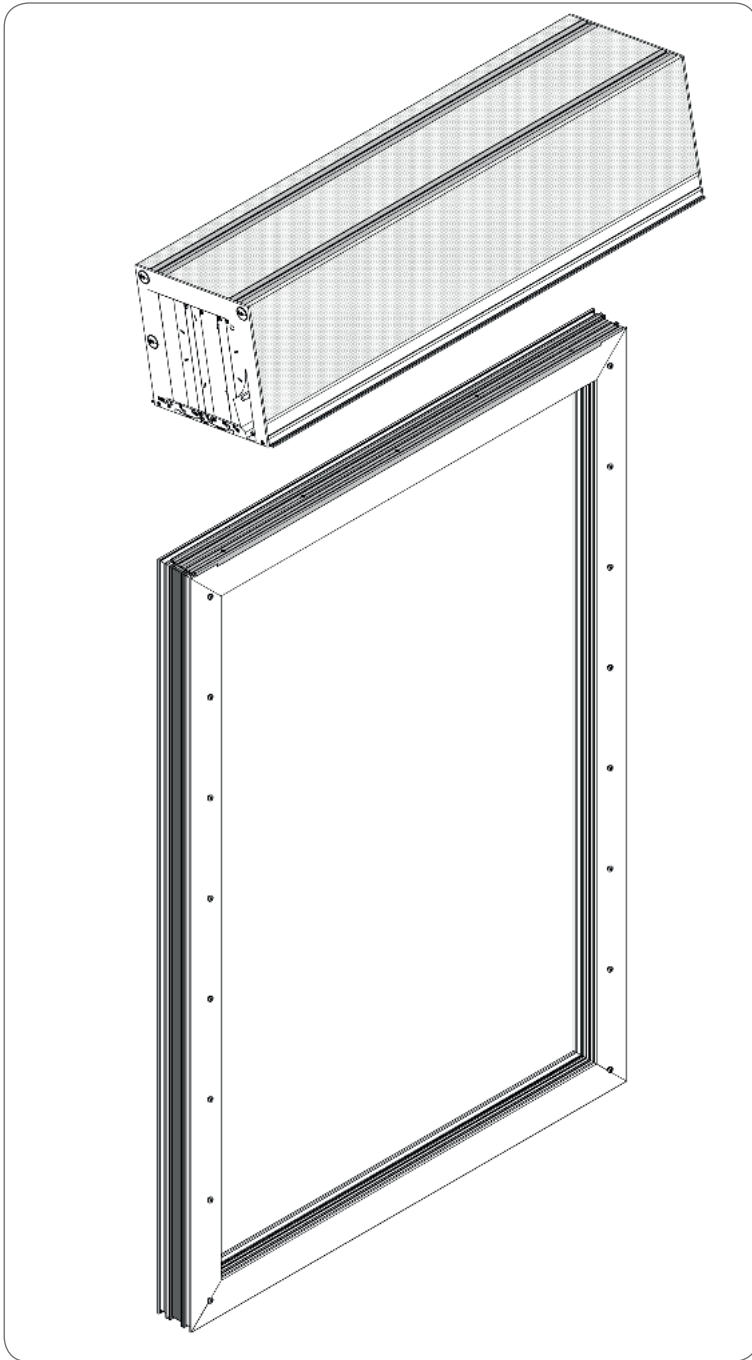

⚠ Die Art und Weise wie man den **SKB/F** i **SKB/F + MKT-Kasten** auf das **Anpassungsprofil** einschiebt

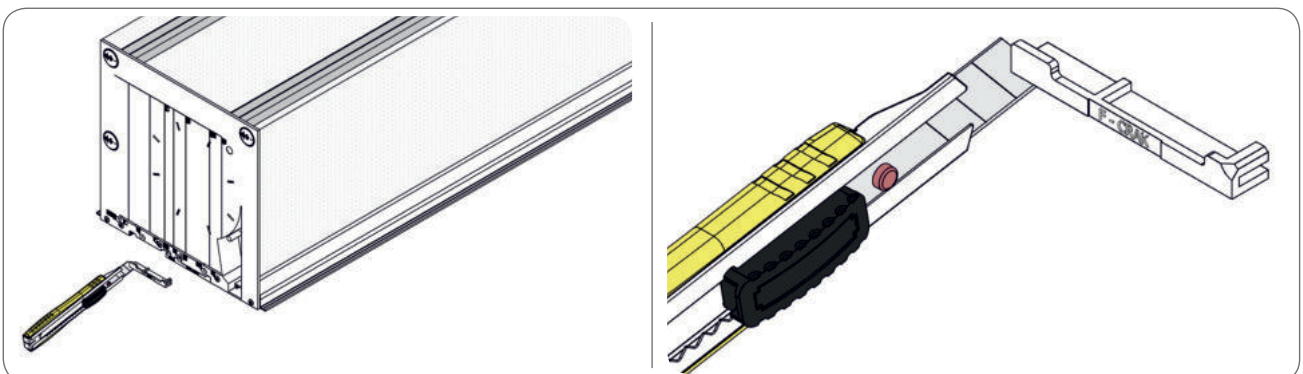
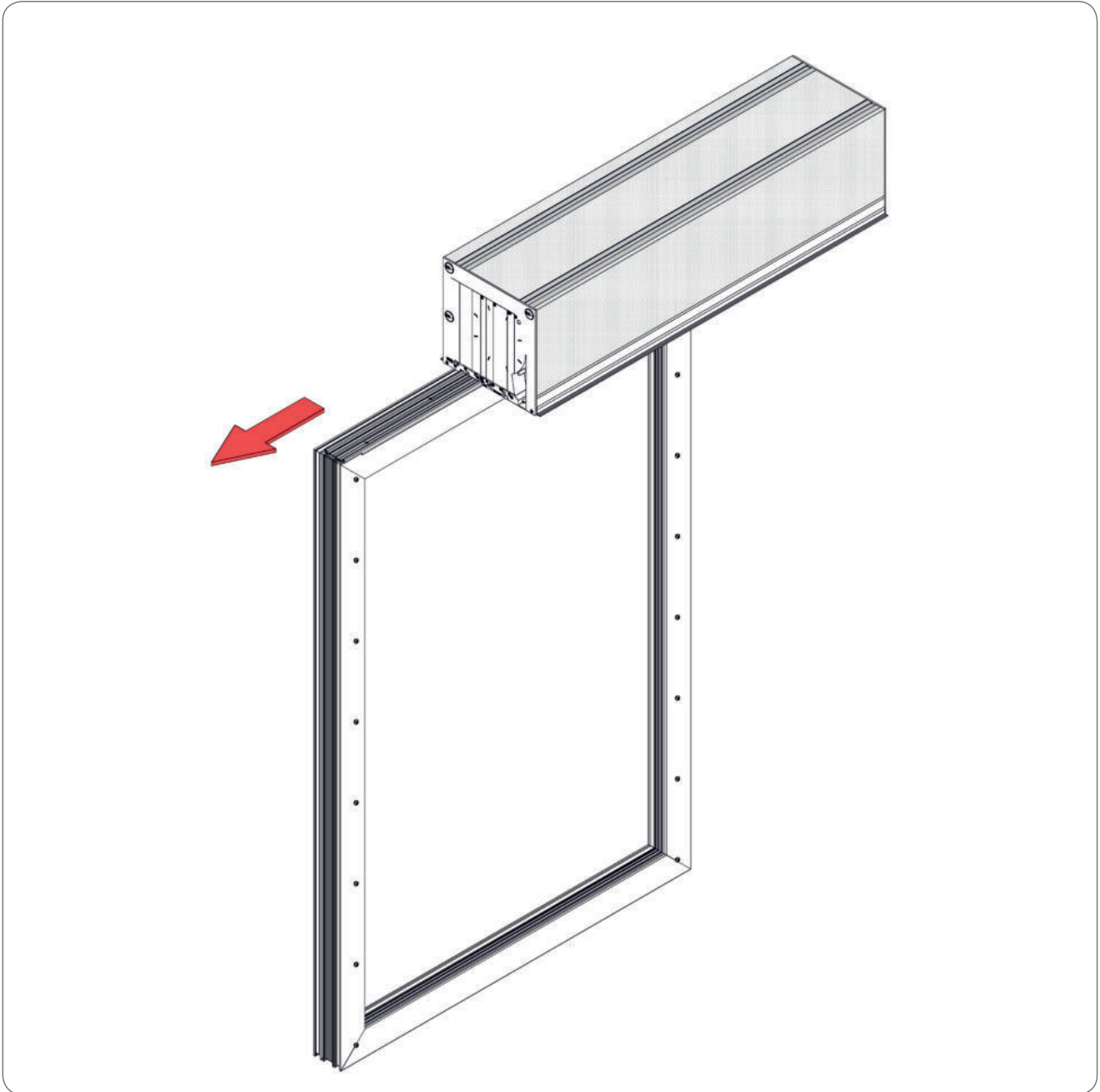

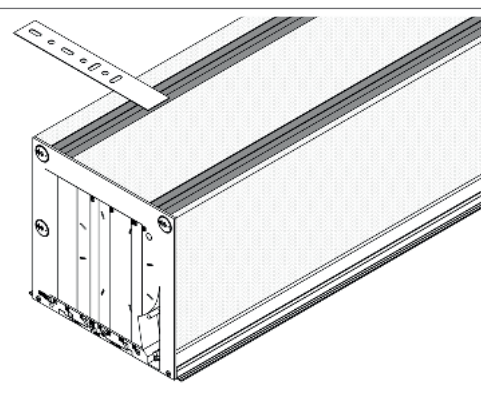
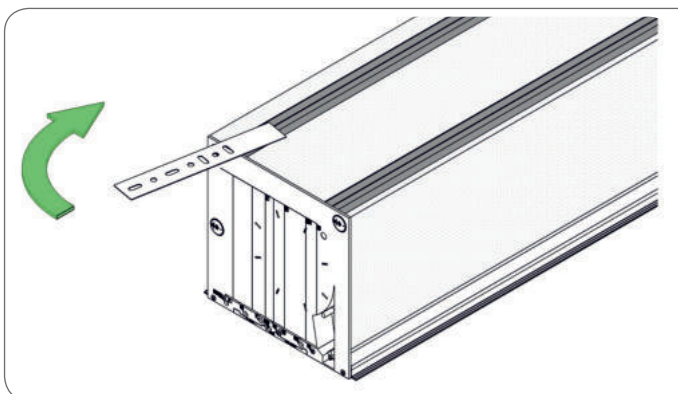
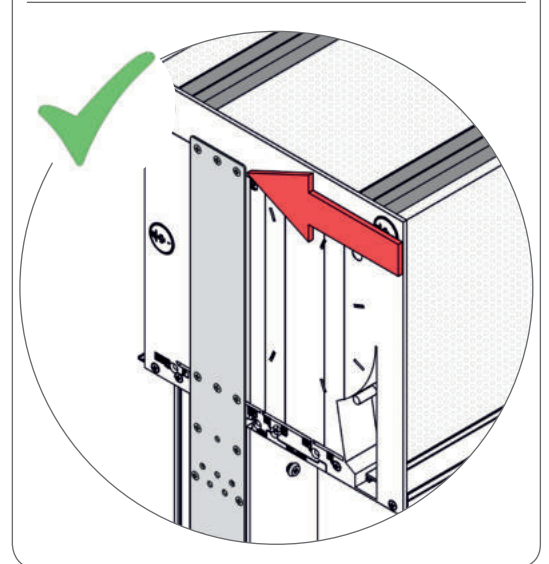
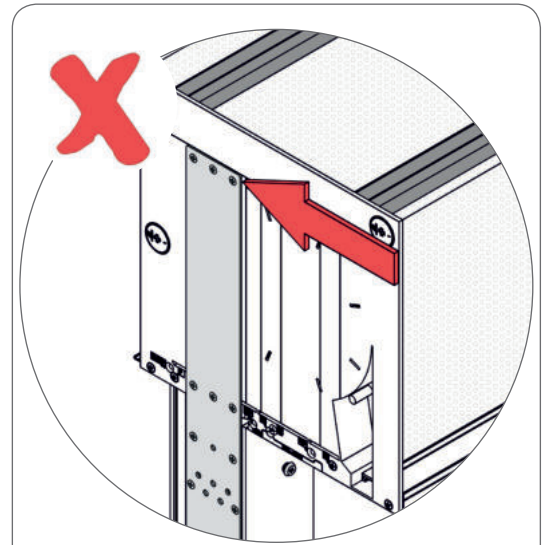
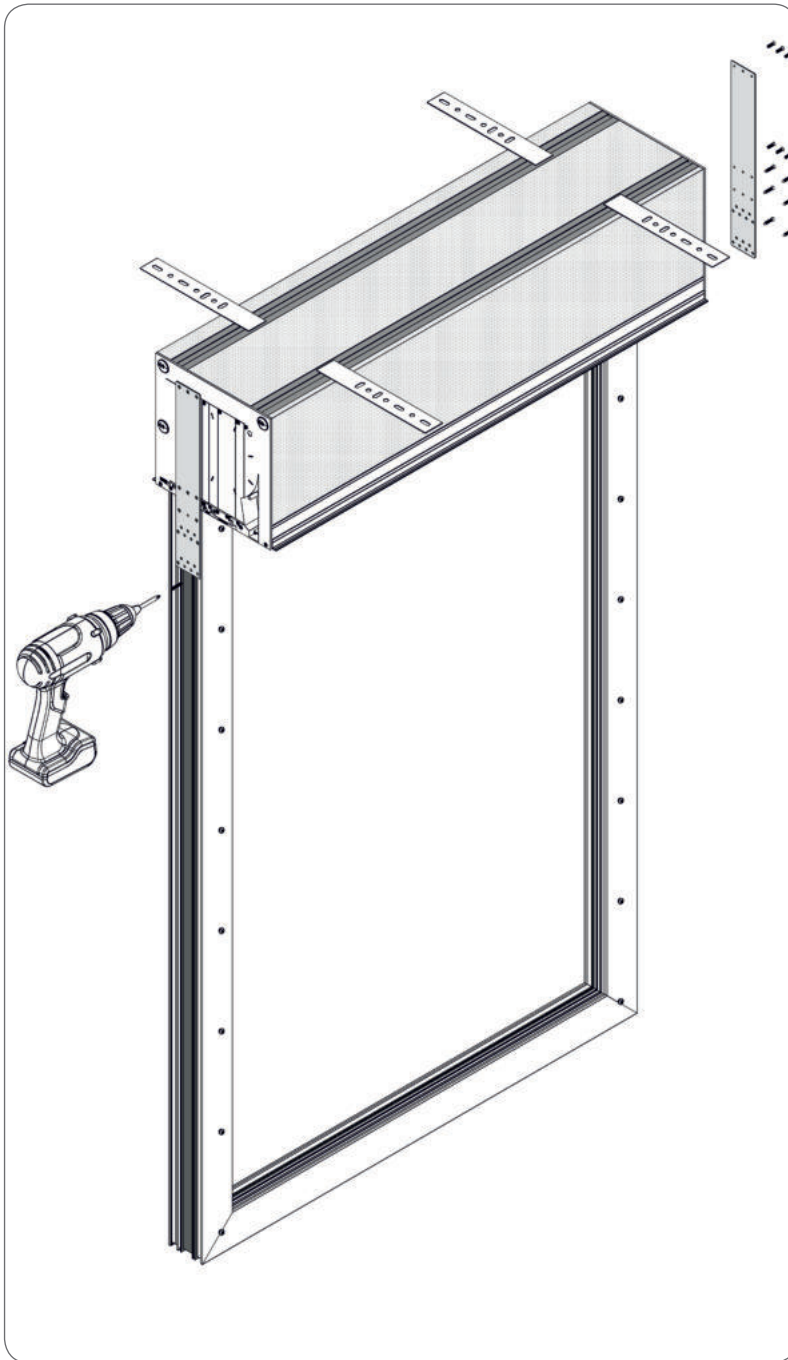

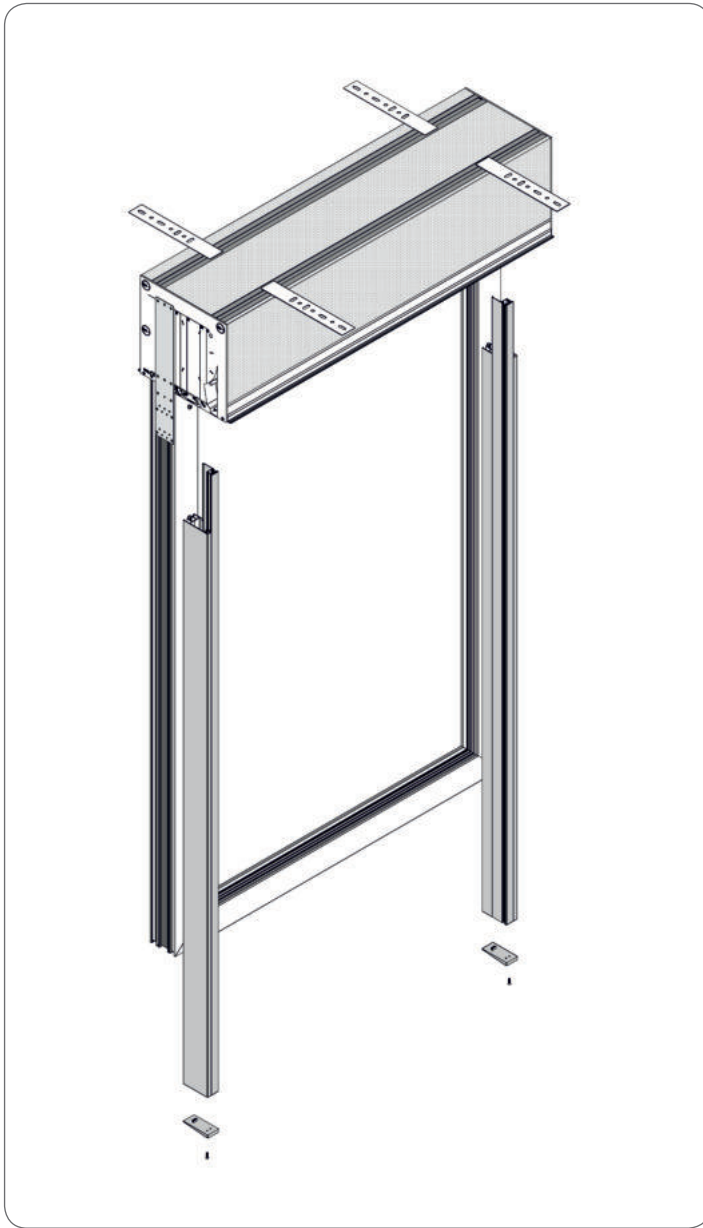

SKB/F

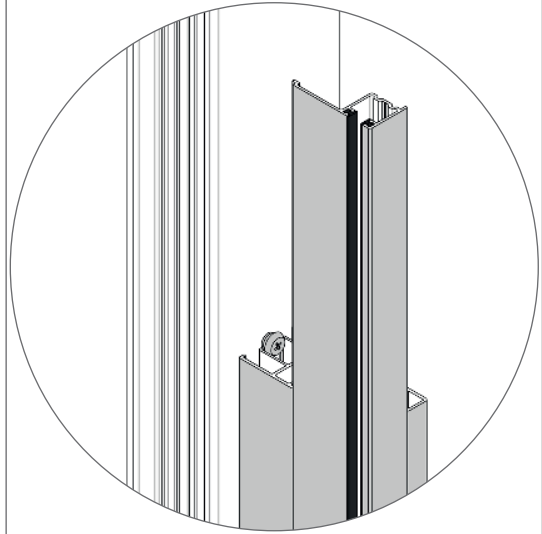

SKB/F + MKT

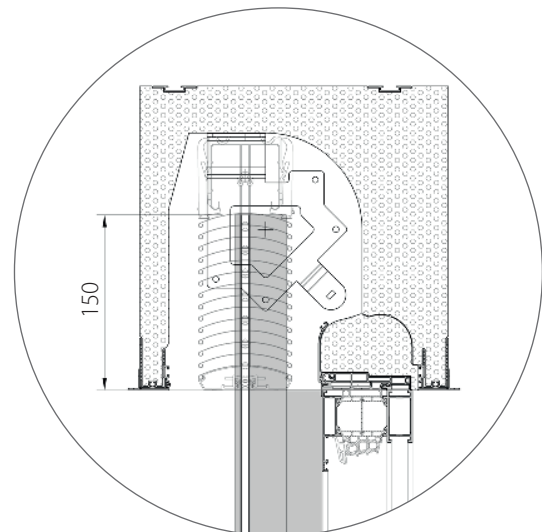
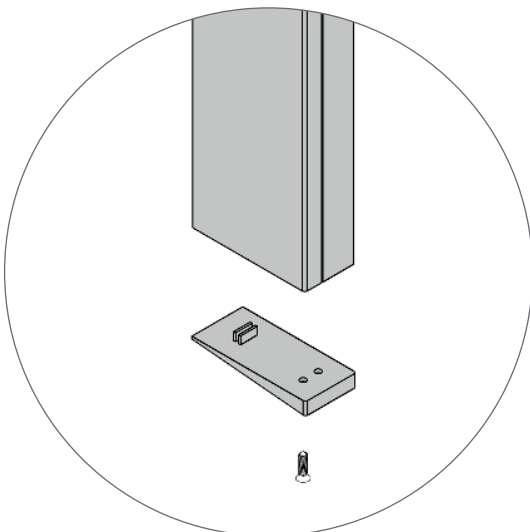
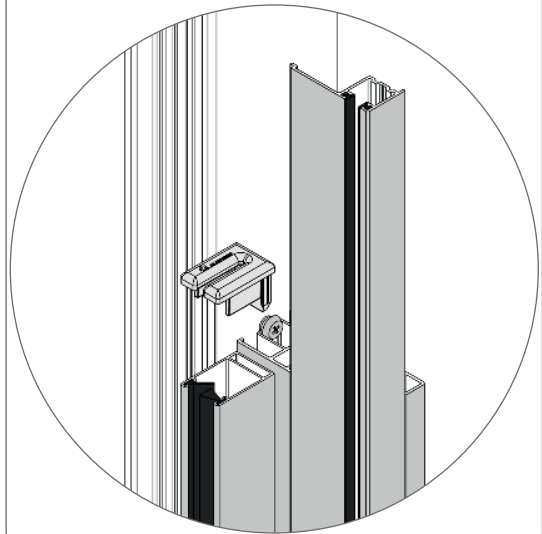

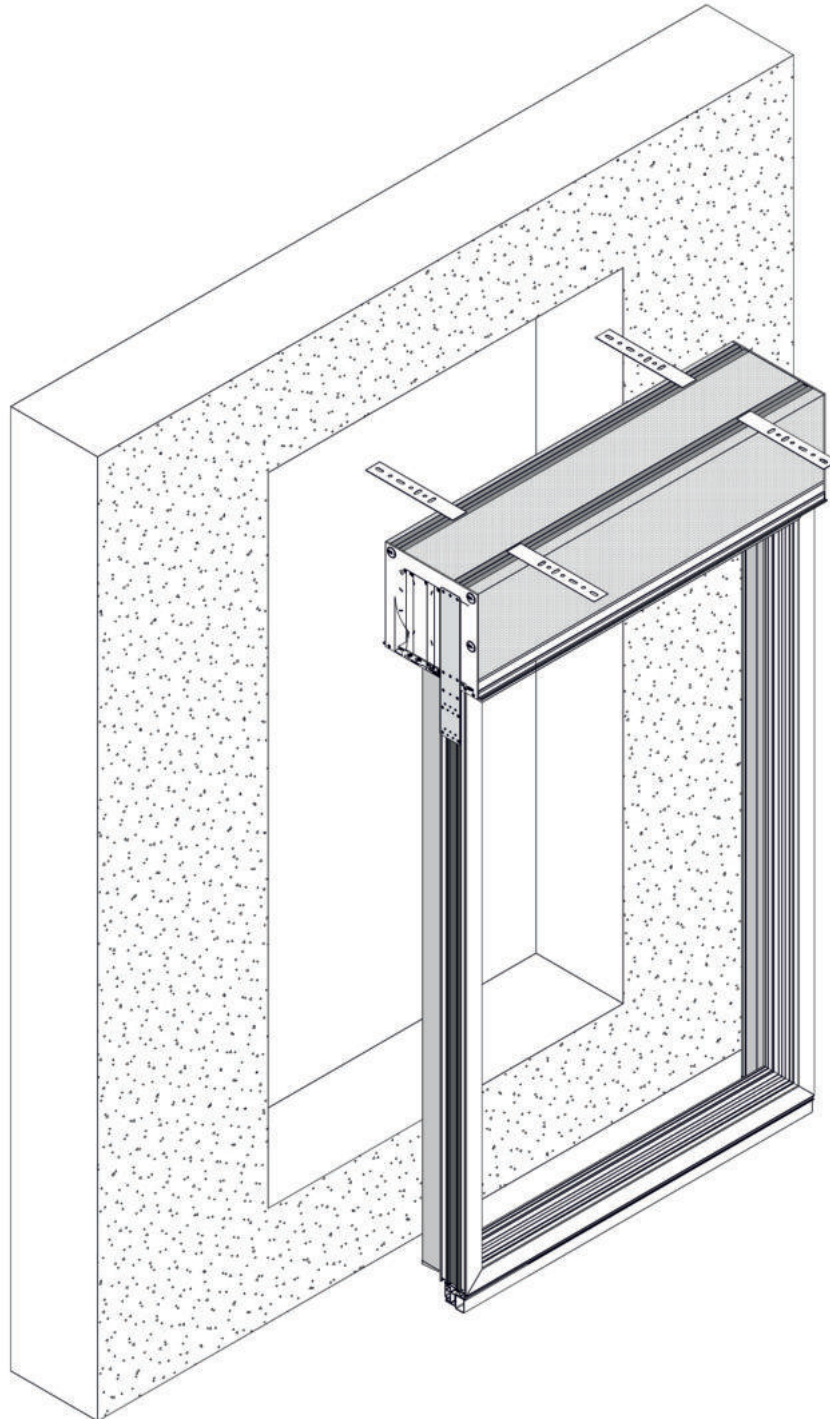

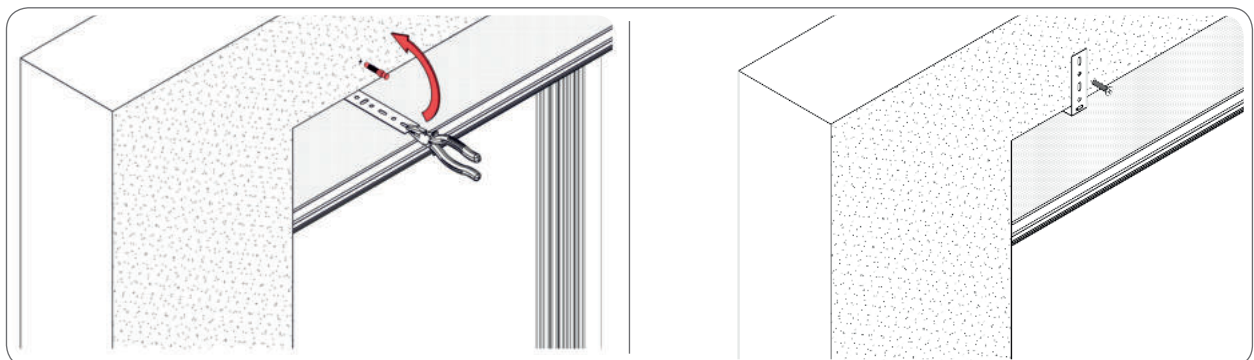

UGF / B-Zwischengriff müssen am Sturz verankert sein. Der Abstand und die Anzahl der Griffe sind nach den Richtlinien des Raffstoreherstellers zu bestimmen.

⚠ Die Art der Verankerung der Klammern sollte in Abhängigkeit von dem Material gewählt werden, aus dem der Sturz hergestellt wurde.

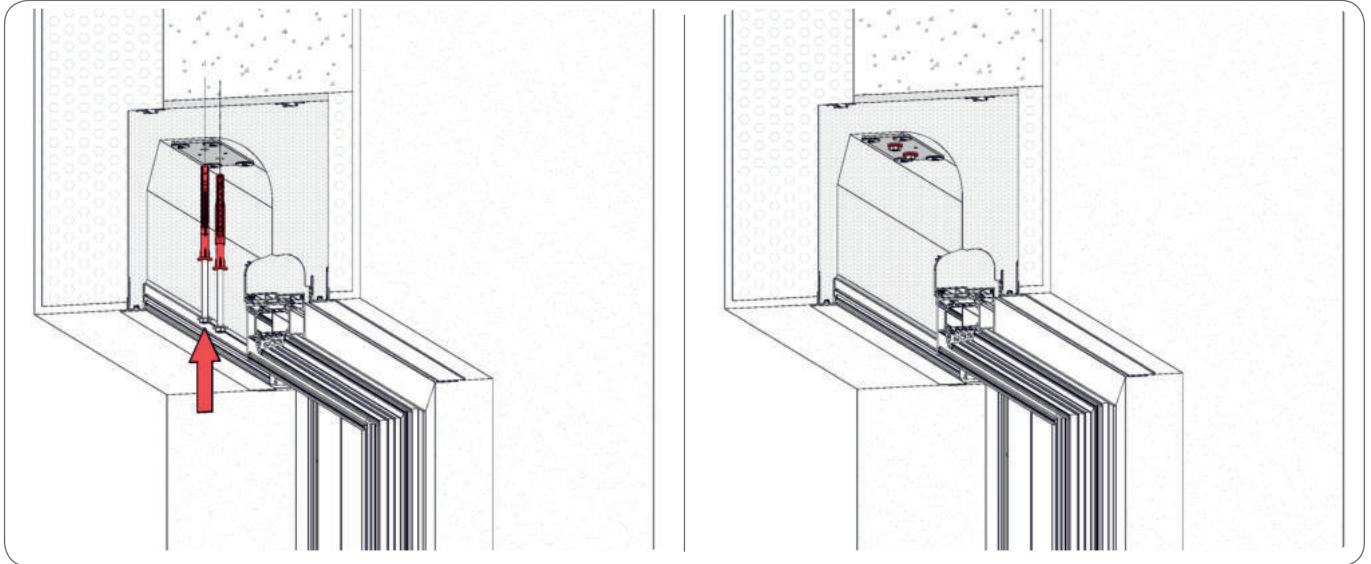

⚠ Es besteht die Möglichkeit einer zusätzlichen Verankerung durch den Hauptgriff der **UBF SKB Raffstore**.

